

**PORT ZIMBALI ESTATE HOME OWNERS'
ASSOCIATION (NPC)**
(Registration Number: 2006/008435/08)

MEMORANDUM OF INCORPORATION
Schedule 5

Rules

The RULES consist of the following documents:

- | | | | |
|----|--|---|---------|
| 1. | Community Participation Rules | - | Page 2 |
| 2. | Accreditation Policy for Estate Agents | - | Page 31 |
| 3. | Conduct Rules for Security Service Providers and Security Officers | - | Page 32 |
| 4. | Architectural Rules and Guidelines | - | Page 34 |
| 5. | Contractor's Code of Conduct | - | Page 56 |
| 6. | Security Policy and Procedures | - | Page 63 |
| 7. | Clubhouse Policy | - | Page 88 |

The documents listed above, where applicable, refer to various lists, annexures, appendices and/or attachments. These lists, annexures, appendices and/or attachments form part of the RULES.

We hereby certify that the RULES as contained herein was adopted by the members of the Association during a duly constituted ANNUAL GENERAL MEETING of the members on 8 July 2023.

Chairperson

Managing Agent

Director



PORT ZIMBALI ESTATE HOME OWNERS' ASSOCIATION (NPC)

COMMUNITY PARTICIPATION RULES

1. INTRODUCTION

- 1.1 One of the main objectives of the Association is the provision of a safe, secure, equitable and high-quality lifestyle for residents. The powers given to the Directors by the Memorandum of Incorporation to create and implement RULES, is for the protection of this objective on the Estate.
- 1.2 Happy and harmonious community living is achieved when members use and enjoy their private property as well as the public areas of the complex in a manner which enables other members the use and enjoyment of their private properties and the facilities on a similar basis. General consideration of all members for each other will greatly assist in achieving a happy community.
- 1.3 In the RULES, if the content of an item or paragraph so dictates, reference to a member will be deemed to include –
- 1.3.1 the member as owner, and in the event of the member being a property-owning entity, the legally appointed official(s) of such entity;
 - 1.3.2 the members of a member's household, family members and employee(s) or staff members;
 - 1.3.3 the member's guests and visitors;
 - 1.3.4 the employees and staff members of a contractor appointed by a member;
 - 1.3.5 in the event a unit being let, the tenant of a member;
 - 1.3.6 the members of a tenant's household and the tenant's guests, visitors and employees;
 - 1.3.7 the employees and staff members of a contractor appointed by a tenant; and
 - 1.3.8 any other person present on the property of a member, with or without the consent of the member.
- 1.4 In the event of disputes between members of any nature whatsoever, the involved parties should attempt to settle the matter between themselves taking the content of the RULES into account, exercising tolerance and consideration in the process.



- 1.5 In the event of any duplication and/or contradiction in and between the Memorandum of Incorporation and the RULES, the relevant provision of the Memorandum of Incorporation will take prevalence for the time-being, it being recorded that the Board of Directors will take the necessary action steps to remove such duplication and/or contradiction from either the Memorandum of Incorporation or the RULES on the basis that original intention of the subject duplication and/or contradiction be recorded where applicable.
- 1.6 The Board of Directors will, if in their opinion it is required, appoint an agent ("Managing Agent") to manage the financial, secretarial, administrative affairs of the Association, as well any additional affairs so directed by the Board of Directors.
- 1.7 Estate Management
- 1.7.1 The Association will, if in the opinion of the Board of Directors it is required, engage the services of an Estate Manager to oversee the day-to-day on-site activities of an operational nature on the Estate, it being recorded that the Association employs various service providers to physically perform access/egress control and maintenance activities on the Estate. Should the Board of Directors elect not to appoint an Estate Manager, the Board of Directors will nominate certain members of the Board to manage the various portfolios (Portfolio Directors) that an Estate Manager would have managed. The Estate Manager or the Portfolio Directors, as the case might be, are referred to in these RULES as Estate Management.
- 1.7.2 The day-to-day on-site operational activities includes the following:
- 1.7.2.1 Ensuring that every person on the Estate, whether member, estate agent, contractor and/or any employee of all of the latter (collectively referred to as "Estate occupants") adhere to the RULES, failing which, to take immediate action steps, as provided for in the RULES, against Estate occupants should such Estate occupants not adhere to the RULES;
- 1.7.2.2 Ensuring that the infrastructure, amenities, landscape and equipment of any nature, developed and/or installed on the Common Property Areas and within servitude areas registered in favour of the Association (collectively referred to as "Estate infrastructure"), are in a sound state of repair at all times, failing which, to take timeous steps to remedy, maintain and restore the disrepair of such relevant Estate infrastructure;
- 1.7.3 The service providers employed by the Association, even though they ultimately report to the Board of Directors and/or the Managing Agent, from a day-to-day on-site operational activity point of view, they operationally primarily report to Estate Management. The following service providers are applicable:
- 1.7.3.1 Security services;
- 1.7.3.2 Fence maintenance services;
- 1.7.3.3 Landscaping services; and
- 1.7.3.4 Domestic refuse removal services.
- 1.7.4 Estate Management is also, subject to approval by the Board of Directors and/or Managing Agent, responsible for temporarily appointing any maintenance service provider to provide a service that is not available from the service providers permanently employed by the Association, as and when it is deemed to be required to ensure the restoration of the disrepair of Estate infrastructure.



2. **DISPUTE RESOLUTION**

2.1 In the event of a dispute between any of the Members or between a Member and the Association, that dispute shall be resolved as follows:

2.1.1 The disputing parties must first attempt to resolve the dispute amongst themselves by taking the content of paragraph 1.4 of The Community Participation Rules section of the RULES into account, failing which;

2.1.2 The dispute will be resolved by the Board of Directors, and in the event of such decision being disputed;

2.1.3 The dispute shall then be referred to The Community Schemes Ombud Service ("CSOS") by registering a dispute in the prescribed manner with CSOS. The following is recorded for convenience purposes:

2.1.3.1 The Community Schemes Ombud Service was established in terms of the Community Schemes Ombud Service Act, 2011 (Act No 9 of 2011) to regulate the conduct of parties within community schemes.

2.1.3.2 The Community Schemes Ombud Service (CSOS) is the regulatory authority for all community schemes in South Africa.

2.1.3.3 It came into operation on 7 October 2016 with the objective to establish the Ombud Service, to provide a dispute resolution process in respect of the conduct of parties in community schemes and the governance of all community scheme is South Africa.

2.1.3.4 Port Zimbali Estate Home Owners' Association (NPC) is a South African community scheme.

3. **RIGHT OF ADMISSION RESERVED AND LIMITATION ON THE LIABILITY OF THE ASSOCIATION**

3.1 The Association shall place such signage at the entrance of the Estate with the disclaimer or similar disclaimer that:

"All persons entering and/or residing on the Estate and/or using the facilities of Port Zimbali Estate Home Owners' Association (NPC) do so at their own and sole risk and by doing so undertake not to hold Port Zimbali Estate Home Owners' Association (NPC) liable for and agree to indemnify Port Zimbali Estate Home Owners' Association (NPC) against any loss, damage, injury or death that may arise from such visit or use, or by reason of any condition on the Estate, or by way of human or mechanical error, default or failure or from any other cause whatsoever, irrespective whether such loss, damage, injury or death was occasioned by the negligence or wrongful act of Port Zimbali Estate Home Owners' Association (NPC), its representatives, agents or assigns."

3.2 The representatives, agents or assigns of the Association is authorised to take such further steps in its discretion to ensure that the aforesaid disclaimer is binding on all persons, entities or organisations not being members of the Estate (hereinafter referred to as "the Third Parties") entering the Estate from time to time, including the requirement for Third Parties to sign and/or enter into such indemnity or disclaimer, whether it be in the form of a ticket contract, contract, stand-alone document or otherwise prior to entry to the Estate, and furthermore authorising the Association's representatives, agents or assigns to refuse entrance to any such Third Parties to the Estate should they refuse to sign and or enter into such indemnity or disclaimer.



- 3.3 In addition to the indemnity displayed under item 3.1 above, every member is hereby explicitly responsible to ensure the safety of their swimming pools as required by Local Authority Regulations and the applicable Laws of South Africa. The safety measures required are intended for all Estate occupants, not only the member and his direct pool-users. As such, the members that have properties that include swimming pools, on becoming a member, hereby indemnifies the Association against any claim of whatever nature, whether injury or loss of life, resulting from the use of a swimming pool whether protected as required by Local Authority Regulations and the applicable Laws of South Africa or not.
- 3.4 The Estate is currently undergoing construction development, it being recorded that various construction activities are taking place on construction sites on the Estate. In addition to the indemnity displayed under item 3.1 above, every member is hereby explicitly responsible to ensure their occupants do not enter such construction sites. As such, on becoming a member, the member hereby indemnifies the Association against any claim of whatever nature, whether monetary, injury or loss of life, resulting from the member or their occupants entering a construction site.
- 3.5 The Estate is protected by an extensive high-voltage electrical fence (the "fence") along its borders. In addition to the indemnity displayed under item 3.1 above, every member is hereby explicitly responsible to ensure their occupants/visitors do not come into contact with the fence. As such, on becoming a member, the member hereby indemnifies the Association against any claim of whatever nature, whether injury or loss of life, resulting from the member or their occupants/visitors coming into contact with the fence.

4. **HEAVY VEHICLES and ROAD FUND**

- 4.1 Heavy vehicles, such as furniture removal, delivery and building material delivery vehicles are allowed access onto the Estate subject to the following conditions:
- 4.1.1 The Gross Vehicle Mass ("GVM") displayed on the licence disc of the vehicle must not exceed 10 ton (10,000 kg);
- 4.1.2 The vehicle must not have a double differential;
- 4.1.3 The vehicle must not have a double axle;
- 4.1.4 The vehicle must not have a horse and trailer configuration;
- 4.1.5 The vehicle must not be an articulated vehicle;
- 4.1.6 The vehicle must preferably be able to park on the drive-way of the relevant property, but if this is not possible, the vehicle may park in the road as long as it doesn't cause an obstruction for passing traffic;
- 4.1.7 The height of the vehicle may not exceed 3,5 metres
- 4.2 Should heavy vehicles not meet the above conditions, a shuttle delivery service must be arranged with the Association.



- 4.3 In the event of a member (including a member's tenant or a contractor employed by a member or a member's tenant), including a contractor or sub-contractor employed by the member requiring a relaxation of the access limitations RULE, application must be made to the Association on the prescribed form (Application for relaxation of the RULE for use of Heavy Vehicle), which is to be delivered to Estate Management and to be approved by the Association, prior to access being granted to such heavy vehicle for which application is made. Each access request will carry a mandatory ROAD FUND contribution, the amount of such contribution being in the discretion of the Association and such contribution being recovered against a member's levy account with the Association.
- 4.4 Concrete, Steel Reinforcing, Brick and Other Building Material delivery vehicles of the Developer, the Main Building Contractor and/or their Subcontractors are however exempt from the rule depicted under paragraph 4.3 above as the Board of Directors have come to an arrangement with the Developer and/or the Main Building Contractor to contribute to the ROAD FUND on the following basis:
- 4.4.1 The Concrete Tariff per cubic meter in respect of concrete delivery vehicles (Steel Reinforcing included herein) as displayed in a document named Levies, Fees, Charges and Recoveries, approved by the members in general meeting from time to time (normally at the Annual General Meeting), and published on the website of the Association (www.pze.co.za).
- 4.4.2 The Bricks Tariff per 1000 Bricks, whether clay, concrete or paving bricks (pavers) (Other Building Material included in the tariff) in respect of brick delivery vehicles as displayed in a document named Levies, Fees, Charges and Recoveries, approved by the members in general meeting from time to time (normally at the Annual General Meeting), and published on the website of the Association (www.pze.co.za).
- 4.4.3 Fill Material (i.e. ground or soil that is used for filling on a construction site) that is used to fill or level a stand to a desired elevation or contour, and which Fill Material is obtained and acquired from outside the boundaries of the Estate, is specifically excluded from this exemption. At every instance that a contractor requires said Fill Material, the ruling contained in paragraph 4.3 above will apply.
- 4.4.4 In the event that the Board of Directors of the Association pass a resolution described in paragraph 7.2 of this Community Participation Rules section of the RULES – namely resolved to allow a member to appoint their own contractor to construct initial dwellings on the Estate - then the subject member is regarded as the Main Building Contractor and therefore qualifies to also be exempt from the rule depicted under paragraph 4.3 above.
- 4.5 The contributions so made and received, are earmarked for the repair of any damage to the road surface, and does not, under any circumstance whatsoever, absolve any member or a contractor or sub-contractor employed by the member from the responsibility of ensuring that damage is not caused to any infrastructure found on the Estate – including items such as the roads, road-surfaces, kerbing, landscaping, road signage, fire hydrants, electrical kiosks, water and sewer installations, etc. In the event of damage of any nature whatsoever being caused, the member will be held accountable for the expense that will need to be incurred to re-instate such damaged infrastructure item to original state.



5. **ENSURING A PLEASING STREETScape**

5.1 Landscaping

- 5.1.1 The landscaping theme of Port Zimbali Estate is the uniform and the exclusive use of indigenous trees, plants and grass (collectively referred to as "plants"). A list of approved indigenous plants is included in the RULES ("Approved Plant List").
- 5.1.2 The boundaries between member's properties comprising the building lines must be landscaped accordingly to create the primary screening for privacy between the properties as the RULES set limitations on the use of garden walls for this purpose – see the Architectural Guidelines.
- 5.1.3 The verges adjacently attached to the properties must be landscaped in a manner to create a uniform streetscape theme as determined by the Board of Directors. Members are obliged to follow this theme on their particular verges.
- 5.1.4 The Association has the right to request any member not complying with the Approved Plant List to have the applicable plants removed and should the Association issue a request to have alien/non-listed plants removed, such member is obliged to effect the subject removal within 14 days of having received the request, failing which the Association has the right to effect the removal for the account of the applicable member.
- 5.1.5 For the purpose of ensuring town planning controls and related regulations of relevant authorities are met as well as achieving landscape uniformity in the landscape, the Association will appoint a qualified landscaping service provider, which will be the sole service provider of this nature on the Estate. To ensure the town planning controls and related regulations of relevant authorities are met the landscaping service provider will, on behalf of and for the account of the member, prepare and present a landscaping plan to the Board of Directors and the relevant authorities for approval. On receipt of approval the member will be bound to the specifics of the installation of the landscape plan so presented in respect of the coverage of lawn/grass areas and the use and positioning of large plant types.
- 5.1.6 Members are responsible for the landscaping of their properties, which includes the initial landscaping of all the relevant verges adjacently attached to such properties, irrespective of whether such verges are on more than one street frontage adjacently attached to such property or not.
- 5.1.7 Members are obliged to utilise the services of the appointed landscaping service provider for all landscaping activities and the maintenance thereof. Members are however entitled to do their own additional landscaping, provided they –
- 5.1.7.1 only use plants included and listed in the Approved Plant List;
 - 5.1.7.2 limit the additional landscaping to their private property (adjacently attached verges are not to be landscaped by the members);
 - 5.1.7.3 comply with the landscaping plan in respect of the coverage of lawn/grass areas and the use and positioning of large tree plant types; and
 - 5.1.7.4 commission the presentation of a fresh landscaping plan should they wish to deviate from the currently approved landscaping plan.

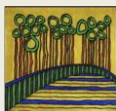

- 5.1.8 Members are not obliged to use the appointed landscaping service provider for initial landscape installations or major overhauls to their existing landscapes. Notwithstanding whether members elect to utilise the appointed landscaping service provider or to utilise an alternate landscaping service provider for initial landscape installations or major overhauls to their existing landscapes, negotiating the project's objectives and the payment of the service provider for work done, is an arrangement between the member and the service provider and the Association bears no responsibility or liability of whatever nature in this regard.
- 5.1.8.1 In the event that a member decides to utilise an alternate landscaping service provider, the alternate landscaping service provider, for the benefit of the member and the Association, must first be accredited with the Association before such alternate landscaping service provider may commence with the new landscape installation or landscape overhaul.
- 5.1.8.2 The member must provide suitable verifiable documentation and present relevant information pertaining to the alternate landscaping service provider to the Association enabling it to perform the accreditation process, which as a minimum must include the following:
- 5.1.8.2.1 A comprehensive company and business profile of the landscape service provider business;
- 5.1.8.2.2 If applicable, copies of formal registration documents, of the business entity;
- 5.1.8.2.3 A CV of the supervising landscaper, manager or business owner;
- 5.1.8.2.4 Copies of the horticultural certificate, diploma or degree of the supervising landscaper, manager or business owner;
- 5.1.8.2.5 Referral information of at least 3 projects pertaining to work performed by the landscape service provider that is not older than 6 months, such as:
- 5.1.8.2.5.1 Names and contact numbers of the employers of the referral projects
- 5.1.8.2.5.2 Photos of the completed referral projects to that comprehensively depicts the nature and extent of the work done
- 5.1.8.2.5.3 An example of a landscape plan utilised for purposes of one of the referral projects.
- 5.1.8.3 Once the alternate landscaping service provider is accredited by the Association, and should the member employ the alternate landscaping service provider to complete the landscaping project, the Association will issue a Construction/Installation Clearance Certificate (see paragraph 15.3), which implies that the alternate landscaping service provider and the member is subject to the rules governing Contractors.
- 5.1.9 The Association will however maintain the landscape of the entire Estate, whether the landscape is on Common Property or on the private property of the members, the cost of which will be carried as follows:
- 5.1.9.1 The cost applicable to the maintenance of the landscape found on Common Property will be for the Association's account, it being recorded that this includes maintenance to the verges of member's properties, even though the work will be carried out during the maintenance of the member's properties;
- 5.1.9.2 The cost applicable to the maintenance of the landscape found on the private property of the members ("member's landscape") will be for the member's account, it being recorded that the Association will recover the amount due for the relevant landscaping service on a monthly basis from the member via the member's levy account held with the Association.



-
- 5.1.10 Landscape maintenance specifically excludes the removal, replacement and/or addition of any plant, grass or vegetation that either has died or is dying from pest infestation or lack of irrigation or fertiliser or as a result of any reason whatsoever, or whether it is overgrown and required to be removed.
- 5.1.11 If in the sole opinion of the Board of Directors a member's landscape has deteriorated to a degree that it has a negative impact on the Estate and/or the surrounding neighbour members and their private properties, the Association has the right to take corrective action, including irrigation or application of fertiliser, to a member's landscape for the subject member's account.
- 5.1.12 Members are obliged to give the employees of the landscaping service provider access to their private gardens on the days and times allocated by Estate Management.
- 5.1.13 The landscaping service provided is as agreed to by the Board of Directors of the Association with the Landscape Service Provider. Estate Management is responsible to advise the members, within a reasonable time after the said agreement is reached, of the nature and extent of the landscaping service the members can expect.
- 5.1.14 No trees shall be removed without the written permission of the Board of Directors. Should a member apply for permission to have a tree removed, the decision of the Board of Directors in this regard is final and the member is obliged to accept this decision. An application must include a neighbour's consent, if the removal of such tree will impact in any way on the neighbour from a privacy and/or shade point of view and it must provide details of the tree and/or shrub that the member will plant in replacement of the tree to be removed.
- 5.1.15 Members shall ensure that declared noxious flora is not planted or growing in their gardens.
- 5.1.16 Members are obliged to use plants in their landscape to shield garden fences and/or screening that does not comply with the type approved by the Board of Directors as more fully described in the Architectural Guidelines of the Association depicted elsewhere in these RULES.
- 5.1.17 Specific rules that apply to Members (for purposes of this paragraph hereinafter referred to as "Private Landscape Members") who elect not to have the maintenance of their private gardens (for purposes of this paragraph hereinafter referred to as "Private Gardens") maintained by the Landscape Service Provider appointed by the Association (for purposes of this paragraph hereinafter referred to as the "Association Landscaper") are as follows:
- 5.1.17.1 All the rules found in The Community Participation Rules and The Architectural Rules and Guidelines sections of these RULES that pertain to Landscaping Maintenance and the Association Landscaper, remain irrevocably in force and will apply to the landscaper appointed by the Members (for purposes of this paragraph such landscaper appointed by the Private Landscape Member will be referred to as the "Private Landscaper").
- 5.1.17.2 Members not eligible to becoming a Private Landscape Member
- 5.1.17.2.1 Members that have let their Property.
- 5.1.17.2.2 Members that do not permanently occupy their homes are not eligible to become a Private Landscape Member.
- 5.1.17.2.3 It is recorded that Members being absent from their homes for periods no more than thirty consecutive days does not affect permanent residency for purposes of this paragraph, but only on condition the absent Member makes suitable/acceptable arrangements for basic garden maintenance to take place during their absence.



5.1.17.3 Application to become a Private Landscape Member

5.1.17.3.1 Members must apply to become a Private Landscape Member with the Association by submitting the relevant completed and signed application form and providing such form to the Association for consideration.

5.1.17.3.2 The Association will, in the sole discretion of the Board of Directors, approve such application on receipt of such application, but only after having received a positive recommendation from the Architectural Review Committee of the Association (the "ARC"). The Association will indicate such approval by issuing a Private Landscape Member Certificate to the Private Landscape Member, which certificate will also bear the date on which Private Landscape Membership becomes effective (hereinafter referred to as the "Effective Date").

5.1.17.3.3 Becoming a Private Landscape Member implies that the Association Landscaper must be given notice that landscape maintenance by the Association Landscaper is no longer required by the Private Landscape Member. To accommodate the subject notice, a period of two calendar months is required, during which time the Private Landscape Member will remain liable to the Association for payment of the monthly Landscape Maintenance Charge regardless of when the Private Landscaper takes over the maintenance of the Private Garden.

5.1.17.4 Landscape Maintenance Charge and Communal Landscape Contribution

5.1.17.4.1 As from the Effective Date –

5.1.17.4.1.1 the cost of maintaining the Private Garden becomes the Private Landscape Member's responsibility;

5.1.17.4.1.2 the Association will cease to recover the monthly Landscape Maintenance Charge from the Private Landscape Member;

5.1.17.4.1.3 the Association will start to recover a monthly Communal Landscape Contribution from the Private Landscape Member, such contribution amount to be utilised for the cost of landscape maintenance attributable to verges (irrespective of whether the Property of the Private Landscape Member has a verge or not) and other communal areas, such as gardens at the Gatehouse entrance and the Clubhouse.

5.1.17.4.2 The following applies to the two landscape charges recovered by the Association from members, namely:

5.1.17.4.2.1 Both recoveries take place monthly on an "in-advance" basis;

5.1.17.4.2.2 Both recovery amounts are determined in accordance with the provisions of the RULES;

5.1.17.4.2.3 Members are advised of both recovery amounts in accordance with the provisions of the RULES;

5.1.17.4.2.4 Members utilising the services of the Association Landscaper are only charged the Landscape Maintenance Charge;

5.1.17.4.2.5 Private Landscape Members are only charged the Communal Landscape Contribution.

5.1.17.5 Obligations of Private Landscape Members

5.1.17.5.1 From a Security Policy and Procedures point of view (see the Security Policy and Procedures section of these RULES), the following will apply:

5.1.17.5.1.1 The Private Landscaper will be dealt with as a Subcontractor to a Main Contractor;



-
- 5.1.17.5.1.2 The Private Landscape Member will be regarded as the Main Contractor;
- 5.1.17.5.1.3 In the event that the Private Landscape Member merely appoints an individual to assist with the maintenance of the Private Garden, such individual will be dealt with as a Domestic.
- 5.1.17.5.2 The Private Landscape Member will be liable for the payment of the monthly Communal Landscape Contribution.
- 5.1.17.5.3 Private Gardens must be maintained on a weekly basis.
- 5.1.17.5.4 Private Landscape Members must maintain their gardens to a minimum standard that is equivalent to other gardens found on the Estate and to a standard that is acceptable to the Association.
- 5.1.17.5.5 Private Gardens can be maintained on any day of the week, excluding on Sundays and Public Holidays.
- 5.1.17.5.6 Maintenance of the landscape found on the road verges of Private Gardens will be the responsibility of the Association.
- 5.1.17.5.7 Removal of garden refuse generated as a result of maintaining Private Gardens from the Estate will be the responsibility of the Private Landscape Member and will be done at the Private Landscape Member's cost, it being recorded that such removal of garden refuse must take place on the day that Private Garden maintenance takes place, unless the garden refuse so generated can be stored completely out of sight from neighbouring members and road users on the Private Landscape Member's Property.
- 5.1.17.5.8 In the event that the Association requests a Private Landscape Member to do remedial work or additional maintenance to his Private Garden, the Private Landscape Member agrees to perform such tasks within seven days from being asked to do so by the Association.
- 5.1.17.6 Rights of the Association pertaining to Private Landscape Members
- 5.1.17.6.1 The Association reserves the right, without giving notice to Private Landscape Members, to inspect their Private Gardens.
- 5.1.17.6.2 The Association reserves the right to request Private Landscape Members to do remedial work or additional maintenance to their Private Gardens.
- 5.1.17.6.3 In the event that the Association finds the state and standard of a Private Garden of a Private Landscape Member to be unacceptable, and such Member fails to remedy the situation and/or fails to implement the Association's requests, the Association has the right to re-appoint the Association Landscaper to maintain the Private Garden, in which instance the Association has the right to recover the monthly Landscape Maintenance Service charge from the member – it being recorded that such recoveries happen on an "in advance" basis.
- 5.1.17.7 Application to revert to garden maintenance to be performed by the Association Landscaper
- 5.1.17.7.1 Members must apply to revert to garden maintenance to be performed by the Association Landscaper by submitting the relevant completed and signed application form and providing such form to the Association for consideration.
- 5.1.17.7.2 The Association will approve such application on receipt of such application, but only after the ARC, supported by the Association Landscaper, has assessed the subject garden and has provided the Association with take-on conditions, if any.
- 5.1.17.7.3 The Association will indicate such approval by issuing a Certificate to the Member, which certificate will indicate the date (hereinafter referred to as the "Resumption Date") on which the Association Landscaper will resume maintenance duties at the subject garden as well as any take-on conditions that requires attention according to the Association Landscaper's assessment.

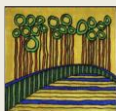

-
- 5.1.17.7.4 The Association will resume recovery of the monthly Landscape Maintenance Charge from the member as from the Resumption Date.
- 5.1.17.7.5 To revert to garden maintenance to be performed by the Association Landscaper, implies that the Association Landscaper must ensure he has sufficient capacity within his work-force on the Estate – for this reason the date on which the Association Landscaper resumes maintenance activities will be two months after the date of receipt of the application form, unless an earlier date is agreed upon by the parties (Member, Association and Association Landscaper).
- 5.2 Garden doors, gates, fences, walls and buildings forming part of the streetscape shall be maintained and painted by members where and when necessary, as determined in the sole discretion of the Board of Directors, failing which the Association may undertake such maintenance and painting on behalf of the member for the subject member's account.
- 5.3 Building material and garden refuse shall not be dumped on the sidewalks under any circumstances.
- 5.4 Garage doors and service area gates shall be kept closed except insofar as is necessary to provide entry and exit.
- 5.5 Caravans, trailers, boats, Wendy houses, tool sheds, equipment, furniture, domestic appliances, building material, tools, engine and vehicle parts as well as accommodation for pets shall be sighted out of view and screened from neighbouring properties. No outbuildings such as carports, Wendy houses or tool sheds for the purpose of housing any of the above shall be erected outside the Architectural Guidelines of the Association as fully described elsewhere in these RULES.
- 5.6 Patio and other open habitable areas of a dwelling that are in full view from the street or neighbouring properties may not be used as storage facilities, it being understood that the furniture utilised in such areas must be patio furniture in nature and specifically excludes typically lounge, bedroom or dining-room styled furniture.
6. **ENVIRONMENTAL MANAGEMENT**
- 6.1 Street usage
- 6.1.1 Save where inconsistent with these rules, the National Road Traffic Act, No 93 of 1996, applies.
- 6.1.2 The speed limit in the Estate is 25 km per hour – all construction vehicles and vehicles in excess of 5 ton must adhere to a speed limit of 15 km per hour.
- 6.1.3 Children may not play in the streets. Parents must ensure that their children comply with this rule. Members, including their tenants, unreservedly agree that the Association will not, under any condition of any nature, be held liable for injury or loss of life to a child in the event of this RULE being breached.
- 6.1.4 The use of vehicles, including motorcycles, which create excessive noise, is prohibited.
- 6.1.5 Roller skates, skateboards and similar devices may not be used in the streets.



6.2 Good neighbourliness

- 6.2.1 Insofar as the objectives of the Association is concerned (see paragraphs 1.1 and 1.2 of this section of the RULES), it is hereby recorded that members must act in a manner that –
- 6.2.1.1 will not bring the reputation of the Association and the Estate into disrepute;
 - 6.2.1.2 respects the privacy of their neighbours; and
 - 6.2.1.3 will not cause a nuisance such as raucous and unseemly behaviour.
- 6.2.2 No business activity or hobby, which could cause aggravation or nuisance to members, including auctions and jumble sales, may be conducted in the Estate.
- 6.2.3 The volume of sound in and arising from a unit, from whatever sources, including radios, television sets, human voices, musical instruments, toys or telephones shall be on such a level so as not to be heard on adjoining properties.
- 6.2.4 Mechanical maintenance work, including the use of power-tools and similar devices, is only permitted between 08:00 – 17:00, Mondays to Saturdays (public holidays excluded).
- 6.2.5 Washing may only be hung on washing-lines that are entirely screened from the streets and neighbours.
- 6.2.6 No advertisements or publicity material, of any person including maintenance contractors, may be exhibited or distributed without the consent of the Association. The Association shall have the right to remove any material exhibited or distributed in contravention of this RULE.
- 6.2.7 Littering in the streets and open spaces is prohibited.
- 6.2.8 Flora may not be damaged or removed from any public area or open spaces.
- 6.2.9 Fauna of any nature may not be chased or trapped in any public area by members or their pets.
- 6.2.10 Swimming pool water must be channelled into the storm water drainage system of the relevant member's property.
- 6.2.11 A member or occupier shall not store any material, or do or permit or allow to be done, any other dangerous act in or on his private property or on the common property that will or may increase the rate of the premium payable by the neighbours or the Association on any insurance policy.
- 6.2.12 Members may not leave any obstruction on any part of the common property which will impede the free flow of pedestrian or vehicular traffic. To this end, members/residents/contractors may not park or leave any vehicle unattended on any road or other common property. In the event of a member/resident receiving a visitor and sufficient parking is not available for such visitor's vehicle, the visitor must park his/her vehicle at the public parking space that is available at the clubhouse. Temporary visitor's parking areas are allocated inside the estate, between the Gate House and the traffic circle. The use of these areas are subject to the use thereof being limited to 6 (six) hours per instance. Any offender of the latter will be subject to a fine determined by the Directors of the Association from time to time – such fine to be collected via the member's/contractor's/service provider's monthly levy/charge account, as the case might be.



- 6.2.13 Members considering the use of a Fuel Driven Power Generator ("FDP Generator"), but not considering the permanent installation thereof, may do so subject to the following conditions:
- 6.2.13.1 Such FDP Generator must possess the following specifications, it being recorded that it is the member's responsibility to provide the Association with formal documentation from the supplier/manufacture depicting the specifications of the FDP Generator to be used, namely:
- 6.2.13.1.1 Noise level - must not exceed 50 dBA @ 7 meters;
- 6.2.13.1.2 Inverter type power generation;
- 6.2.13.1.3 Maximum power delivery - 4 Kva with 1,5 Kva Duty Cycle.
- 6.2.13.2 During operation the FDP Generator must be kept in a closed garage, which step is intended to reduce the noise level during operation to 30 dBA @ 7 meters. Should this not be the case in any given instance, the Association reserves the right to impose additional conditions on the member utilising a FDP Generator in this non-permanent installation manner.
- 6.2.13.3 It being recorded that the member is obliged to ensure that total and comprehensive provision has been made for the fumes of the FDP Generator to exhaust to the outside of the garage.
- 6.2.13.4 Operation of the FDP Generator is not allowed before 06:30 or after 21:00 on any given day. For purposes of clarifying a current provision contained in the RULES, be advised that a FDP Generator is considered to NOT be a power tool.
- 6.2.13.5 The use of FDP Generators by members is done so entirely at their own risk and it is hereby recorded that the indemnity disclaimer of the Association specifically and irrevocably applies.
- 6.2.14 Members considering the use of a FDP Generator that will be permanently installed must follow the process contained in the Architectural Rules and Guidelines for such installation. The operation of such FDP Generator is not allowed before 06:30 or after 21:00 on any given day.
- 6.3 Refuse disposal
- 6.3.1 The by-laws of the Local Authority relating to refuse disposal applies to the Estate. In the event of a conflict between the by-laws and these RULES, the stipulations of the RULES shall prevail.
- 6.3.2 The Association will appoint a Domestic Refuse Removal service provider and a Landscaping service provider. These service providers are responsible for the removal of relevant refuse in terms of their contractual arrangements with the Association.
- 6.3.3 The Association may from time to time elect to implement refuse recycling operations and procedures on the Estate.
- 6.3.4 In respect of domestic refuse, members must –
- 6.3.4.1 be in possession of the prescribed refuse bin, failing which, acquire a prescribed refuse bin, for depositing domestic refuse;
- 6.3.4.2 maintain their refuse bins in a hygienic and dry condition and keep the refuse bin within the courtyard area of his private property;



- 6.3.4.3 only deposit domestic refuse contained in plastic refuse bags in the refuse bins – it being recorded that the service provider will provide the members with black plastic refuse bags on a regular basis – and ensure that the refuse bins are secured so as to ensure that monkeys are not able to access them, thus ensuring that refuse is not deposited or littered on the Estate by the monkeys;
- 6.3.4.4 place the refuse bin outside the dwelling before 08:00 on collection days and return it to the courtyard area as soon as possible after the refuse has been collected, in any event by no later than 18:00 on the relevant collection day.
- 6.3.5 Members may not dispose of any waste, item, article or substance in either their private refuse bins or the refuse bins in the refuse area that is either poisonous, a health hazard or detrimental to the safety of the owners or occupants of the Estate. Such waste, items, articles or substances must be disposed of as prescribed by the by-laws and regulations of the Local Council relevant to such waste, items, articles or substances.
- 6.3.6 The refuse area situated at the ablution-block adjacent to the gate-house
- 6.3.6.1 The refuse area situate at the ablution-block adjacent to the gate-house is NOT for use by members/residents/contractors. It is strictly for use by the guards and landscaping staff only, AND ONLY for their normal household type refuse.
- 6.3.6.2 Depositing of card-board boxes, their wrapping and packaging materials, old furniture and appliances, bicycles and any other item that cannot be disposed of via normal refuse bins may not be left at this area for disposal.
- 6.3.6.3 Any person found breaching this rule will be subject to a fine and the cost of the removal of applicable items, it being recorded that such cost will be punitive in nature.
- 6.3.7 All building rubble shall be removed by members and/or contractors at their own cost.
- 6.3.8 The burning of rubble of whatever nature within the Estate is forbidden.
- 6.4 Fires and Fireworks
- 6.4.1 The by-laws of the Local Authority relating to fires and fireworks apply to the Estate. In the event of a conflict between the by-laws and these RULES, the stipulations of the RULES shall prevail.
- 6.4.2 Open fire braais are allowed at a member's unit, but on condition that the fire must be in a dedicated built braai or other infrastructure item suitable for open fires.
- 6.4.3 The setting off of fireworks and the launching of Chinese lanterns are not allowed.
- 6.5 Eradication of pests
- 6.5.1 The by-laws of the Local Authority relating to pests apply to the Estate. In the event of a conflict between the by-laws and these RULES, the stipulations of the RULES shall prevail.
- 6.5.2 A member shall keep his unit free of white ants, borer and other wood destroying insects, all other insect infestation types (such as fleas, cockroaches, fish moths, etc.) and rodents (such as rats, mice, etc.) and to this end shall permit the Association, the managing agent, and their duly authorised agents or employees, to enter his or her unit from time to time for the purpose of inspecting the unit and taking such action as may be reasonably necessary to eradicate any such pests.



- 6.5.3 The costs of the inspection, eradicating any such pests as may be found within the unit, replacement of any infrastructure belonging to the Association that may be damaged by any such pests shall be borne by the member of the unit concerned.

7. **DEDICATED BUILDING CONTRACTOR**

- 7.1 To maintain the integrity of the security systems and policies of the Estate, to minimise building construction activities and building construction personnel on the Estate and to reduce the risk of damage to Estate infrastructure the Association has agreed that the Developer will have the primary right to appoint the Main Building Contractor on the Estate.
- 7.2 The above ruling only pertains to the construction of initial dwellings on the Estate (in other words, the first building construction work on a property of a member), unless the Developer recommends to the Board of Directors of the Association that members be allowed to appoint their own building contractor to construct initial dwellings on the Estate and the Board of Directors of the Association resolves to approve such recommendation, in which case members will be allowed to appoint their own building contractor to construct initial dwellings on the Estate subject to conditions either set out in these RULES or as additionally set by the Board of the Association.
- 7.3 Members are however entitled to appoint their own contractors to do alterations, renovations and/or building additions to the initially built dwellings (refer to paragraph 10 for further details).
- 7.4 Under the circumstances described under paragraphs 7.2 and 7.3 above where a member appoints their own contractor to construct initial dwellings on the Estate or to do alterations, renovations and/or building additions to initially built dwellings, the subject member is regarded as the Main Building Contractor and the contractors he appoints are regarded as his sub-contractors for all purposes contained in these RULES.

8. **SECURITY**

- 8.1 The high standard of the security in and on the Estate, but more importantly the objective of not only continually sustaining the high standard of the security enjoyed, but also the striving to enhance and improve on this standard, is one of the primary reasons members and/or their tenants have chosen to reside on the Estate and/or have chosen to invest in the Estate. To achieve this objective, the Association -
- 8.1.1 has documented the detailed Security Policies and Procedures found elsewhere in the RULES;
- 8.1.2 endeavours to employ the best possible security service provider within its means to apply the Security Policies and Procedures;
- 8.1.3 has installed security infrastructure, such as computerised security access/exiting systems, booms, gates, communication systems and electric fencing to assist the security officers of the security service provider;
- 8.1.4 will ensure the security infrastructure remains in top working condition at all times by applying pro-active maintenance procedures to the infrastructure and, where necessary, appointing relevant maintenance service providers;



- 8.1.5 will ensure that the boundary/perimeter fence (encompassing the electric fence installation) of the Estate is patrolled on a daily basis by both security and, where applicable, electric fence maintenance staff – it being recorded that:
- 8.1.5.1 members of units bordering the boundaries of the Estate are obliged to grant access to security and electric fence maintenance staff for the fence found along their boundaries to be patrolled from a security perspective and checked from a maintenance perspective;
- 8.1.5.2 members must ensure that a pathway at least one meter wide exists along the boundary fence, with clear access from one unit to another, it being recorded that the use of pedestrian gates are acceptable should members require these for the control of their pets;
- 8.1.5.3 members of unit numbers 491 to 497 are not subject to the “clear access from one unit to another stipulation”, however, providing access to the fence for maintenance purposes remains a requirement;
- 8.1.6 places the obligation on its members and other Estate occupants to adhere, without fail, to the Security Policies and Procedures at all times; and
- 8.1.7 expects its members to maintain, enhance and improve the standard of the Estate’s security by *becoming and being part* of a holistic security solution.
- 8.2 All Estate occupants, whether members, and their family members, tenants, contractors and employees or contractors and their supervisors and employees are prohibited to interfere with the security officers in the performance of their duties. They may under no circumstances be abused verbally. Estate occupants shall treat the security officers courteously and co-operate with them in the performance of their duties and no Estate occupant shall be allowed to issue any instructions or directions to the security officers. All suggestions and complaints in this regard shall be directed to Estate Management to either deal with or to present to the Board of Directors for their consideration.

9. **OCCUPANTS, TENANTS, VISITORS, CONTRACTORS AND EMPLOYEES**

- 9.1 No unit may be used as a commune. A unit shall not be occupied by more than one family, subject to a maximum occupancy of 2 (two) persons for every bedroom in the unit – for purposes of this calculation, children under the age of 12 are counted as half. In the event of a member utilising portions of his/her unit as a second dwelling, an additional levy will be become payable by the member to the Association.
- 9.2 The occupiers of units are liable for the conduct of their visitors, contractors and employees, and shall ensure that such persons adhere to these RULES.
- 9.3 Only one full time staff member per unit shall be allowed to dwell on the Estate. No overnight visitors shall be allowed for such staff members.
- 9.4 Staff members shall not congregate or loiter in the streets, on sidewalks or in other open spaces.
- 9.5 No unit may be used as a business premises.



10. **ADDITIONS AND ALTERATIONS**

- 10.1 No additions or alterations whatsoever to any dwelling and, if applicable, its outbuildings shall be effected without the prior written approval of building plans by the Association, other regulatory bodies as described in the Port Zimbali Town Planning Scheme, regulated by ZEMA, and the Local Authority, it being recorded that such additions or alterations must comply with the Architectural Rules and Guidelines of the Association as fully described elsewhere in these RULES.
- 10.2 Other additions that are subject to the approval of the Association, and which, as and where applicable, may also be subject to the approval of the Local Council, include but not limited to, the following:
- 10.2.1 Swimming pools and swimming pool safety fencing;
- 10.2.2 Garden fencing and/or screening;
- 10.2.3 Installation of air conditioning systems;
- 10.2.4 Installation of solar panel systems;
- 10.2.5 Installation of swimming pool heating systems;
- 10.2.6 Installation of items to enclose open patios;
- 10.2.7 Installation of Noise Containment Units to house Fuel Driven Power Generators;
- 10.2.8 Installation of water storage tanks.
- 10.3 Where the Association is empowered to dispense with the requirement of building plans, it will require a complete and accurate description in writing supported by relevant imagery in lieu thereof. This rule does not absolve any member from complying with the requirements of the local authority.

11. **PETS**

In the event that any member and/or resident and/or estate agent refers to the Estate as being "Pet Friendly", whether such referral is done verbally, via press or other media format, such referral is done on the basis that it implies the rules in respect of pets contained in this paragraph 11. Therefore, in the interest of the promotion of good neighbourliness on the Estate, members of the Association or their tenants (in this paragraph 11 referred to as "Residents") will be allowed to keep Pets on their properties (in this paragraph 11 referred to as a Unit) at Port Zimbali Estate, but subject to the following conditions:

- 11.1 The by-laws of the Local Authority relating to pets apply to the Estate. In the event of a conflict between the by-laws and these RULES, the stipulations of the RULES shall prevail.
- 11.2 The total number of dogs and/or cats a member/tenant/resident may keep on the Estate is 3 (three), subject to the limitations below.



-
- 11.3 Pet Clearance Certificate
(Only applicable to dogs and cats)
- 11.3.1 Every Resident that would like to keep a Pet on the Estate must obtain a Pet Clearance Certificate from the Association, which will be issued by the Association on receipt of the form "Application to keep a Pet on the Estate" available for download from the Association's website (www.pze.co.za), such form to be accompanied by the documents described below.
- 11.3.2 The Application to keep a Pet on the Estate form must be fully completed and signed by the Resident (in the event of a Resident being a Tenant, the member must also sign the form) and must be provided to the Association.
- 11.3.3 The Resident must also provide the Association with photographs, in electronic format and via e-mail, of the particular Pet.
- 11.3.4 Pets must be sterilised (spayed and/or neutered) and a certified copy of a certificate from a registered veterinarian must accompany the duly completed and signed application form.
- 11.3.5 A certified copy of a certificate from a registered veterinarian certifying that the pet has had its annual inoculations, specifically including inoculation against Rabies, and which must indicate the date on which the inoculations were administered (hereinafter referred to as the "Inoculation Certificate"), must also accompany the duly completed and signed application form. The Association regards such inoculations to be valid for a 12-month period. Consequently, the Pet Clearance Certificate issued by the Association will expire 12 months after the date on which the inoculations were administered. The pet owner is obliged to provide the Association with a fresh Inoculation Certificate prior to the expiry of the current Pet Clearance Certificate, on receipt of which the Association will issue a fresh Pet Clearance Certificate valid for a further 12 months.
- 11.3.6 The Association reserves the right to charge a fee for issuing Pet Clearance Certificates, and issues and charges for the certificates at its sole discretion.
- 11.4 Dogs
- 11.4.1 No Resident may keep more than 2 (two) dogs on a Unit.
- 11.4.2 The Association reserves the right to be introduced to the dog before making the decision to issue a Pet Clearance Certificate.
- 11.4.3 The Association reserves the right to specify additional conditions, in its sole discretion, before issuing a Pet Clearance Certificate. The Association has the right to require that these conditions are met before the dog may be brought onto the Estate.
- 11.4.4 Notwithstanding any other conditions set, a portion of the garden of a Unit must be fenced off to the satisfaction of the Association, to create an area on the unit for dogs to roam freely, so as to ensure that dogs do not "escape" from the relevant unit and then roam on any Common Property Area or neighbour's units unattended. The subject fencing must be installed to the fencing specification prescribed in these RULES.
- 11.4.5 Dogs shall be walked on a leash when on Common Property Area (i.e. streets, verges and clubhouse gardens) and may not encroach onto neighbouring units.



- 11.4.6 Every dog must wear a collar with an identification tag depicting its name, as well as the name, telephone number and address of its owner. The Association is empowered to apprehend and hand over to the Local Authorities any dog found roaming any Common Property Area without identification tags.
- 11.5 Cats
- 11.5.1 Residents may NOT keep more than 2 (two) cats on a unit.
- 11.5.2 Owing to the prevalence of feral cats on the Estate, when the Association issues Pet Clearance Certificate for a cat, the Association will also issue the cat owner with a tag depicting a registration number for the cat for which the certificate was issued. The owner is obliged to attach the tag to the collar that a cat must wear. This will assist with the identification of cats that roam the Estate.
- 11.5.3 Every cat must wear a collar with the identification tag depicting its registration number. The Association is empowered to apprehend and hand over to the Local Authorities any cat found roaming any Common Property Area without identification tags. In addition to the latter, cats must also wear a bell on the subject collar to act as a "hunting" deterrent.
- 11.5.4 The Association acknowledges that cats will naturally roam areas beyond the boundaries of the cat owner's unit on the Estate. Even though roaming is acknowledged by the Association, cats must not become a nuisance to other residents on the Estate. The following are guidelines that the Association and its members must employ when determining whether a cat is a nuisance, namely:
- 11.5.4.1 A cat roaming in the garden or driveway of another resident is not considered a nuisance;
- 11.5.4.2 A cat roaming on the patio, veranda or stoep of another resident is considered a nuisance;
- 11.5.4.3 A cat entering the dwelling ("being inside the dwelling") of another resident is considered a nuisance;
- 11.5.4.4 A cat climbing onto and soiling garden and/or patio furniture of another resident is considered a nuisance.
- 11.6 Other animals and pets
- 11.6.1 No poultry, pigeons, aviaries, rabbits (even if kept in hutches), wild animals, exotics (such as reptiles, spiders, etc.) or livestock (such as sheep, cattle, goats, etc.) may be kept within the Estate.
- 11.6.2 Parrots, parakeets, budgies and similar domesticated birds are allowed if caged, but residents need to give special attention to the area at the unit where they are kept so as to minimise the noise and nuisance factor such caged birds generate.
- 11.7 General rules
- 11.7.1 It is the responsibility of the Resident to ensure that adequate provision is made for Pets when the Pet owner is absent from the Estate, as it is under these circumstance that Pet nuisance is prevalent.
- 11.7.2 Temporary Residents on the Estate (for purposes of this paragraph 11, "Temporary" means any period less than 30 consecutive days) are not allowed to keep Pets or bring Pets onto the Estate. In instances where periods in excess of 30 consecutive days is applicable, the Resident is obliged to obtain a Pet Clearance Certificate from the Association.



- 11.7.3 The owner of any Pet shall immediately remove any excrement deposited by such Pet in any Common Property Area or any area belonging to neighbours or other members. Excrement of Pets on the private property of the Pet's owner must also be removed timeously to avoid any possible health risk or unwanted odours. The Association may remove excrement on behalf of a Resident, the cost of which will be for the member's account, if deemed necessary and in the sole discretion of the Board of Directors, it being recorded that such cost will be punitive in nature.
- 11.7.4 The breach of any item contained in the RULES pertaining to Pets will attract penalties and fines as provided for in the RULES of the Association, the imposition thereof being in the sole discretion of the Board of Directors.
- 11.8 The Association, in the sole discretion of its Board of Directors, is empowered to require an owner of a Pet to dispose of his/her Pet should it become a nuisance on the Estate or should it affect the safety of other Residents and/or their Pets on the Estate, failing which the Association may have the Pet removed, the cost thereof being for the member's account.

12. **USE OF FACILITIES**

The Board of Directors shall be entitled upon the written application of a member and upon such terms and conditions as may be prescribed by the Board of Directors from time to time to permit:

- 12.1 any person occupying a unit through or at the instance of the owner thereof, the use and enjoyment of the facilities and amenities of the Estate,
- 12.2 the leasing of a Unit to a tenant by the owner of the Unit, provided:
- 12.2.1 that such permission is evidenced by a certificate issued by the Managing Agent, which certificate will be issued subject to the following provisions being met and on condition these provisions are met before occupation is granted to such tenant, namely:
- 12.2.1.1 The Association must be provided with a copy of the relevant lease agreement, signed by the member and his/her tenant;
- 12.2.1.2 The lease agreement must specifically provide for the beneficial rights of the Association in so far as that the tenant:
- 12.2.1.2.1 Undertakes to adhere to and obey the RULES of the Association and the tenant furthermore undertakes to ensure that his family, visitors, contractors and staff members adhere to and obey these RULES; and
- 12.2.1.2.2 Acknowledges that he is in receipt of a copy of the RULES (as amended) and that he understands the content thereof.
- 12.2.1.3 The Association must be provided a duly signed and completed form styled "Annexure B" as annexed to the Security Policy and Procedures of the Association of which the latter forms an integral part of the RULES of the Association;
- 12.2.1.4 The Association must be provided with a certified copy of the identity document of the tenant;
- 12.2.1.5 The Association must be paid the amount due for registering access to the Estate for the tenant, his/her family members and domestic servants – the applicable amount will be recovered via the member's levy account held with the Association;



- 12.2.1.6 In the event of the tenant having a domestic servant, access registration of the domestic servant is required, which will be fulfilled on condition full particulars are provided to the Association – this includes a duly signed and completed form styled “Annexure C” as annexed to the Security Policy and Procedures of the Association of which the latter forms an integral part of the RULES of the Association. The Association must be provided with a certified copy of the identity document of the domestic servant;
- 12.2.1.7 Upon receipt of the required documentation, and subject to the Association finding such documentation satisfactory and complete, the Association will issue a Tenant Clearance Certificate to the member approving access to the Estate for the tenant for the period of the lease. Access registration will only be activated for the lease period in question. Any extension/renewal of lease will require the above process to be repeated;
- 12.2.1.8 A Tenant Clearance Certificate will only be issued on condition member’s levy account with Association is up to date and not in arrears. The member remains responsible for monthly amounts levied by the Association on the member for levies and other services rendered;
- 12.2.1.9 A Tenant Clearance Certificate fee of R570, the amount of which is in the discretion of the Association is payable by the member/owner - the amount will be recovered via the member’s levy account with the Association;
- 12.2.1.10 The Association is in no manner whatsoever responsible for the recovery of landscaping maintenance charges or water and sewerage provision and usage charges applicable to the tenancy from a tenant – this remains the sole responsibility of the member/owner.
- 12.2.1.11 Specific attention is drawn to the limitation placed on the number of occupants per unit – four per bathroom. Under no circumstances may a unit be utilised as a commune.
- 12.2.1.12 The Managing Agent is obliged to manage the letting compliance process specified above, for which it may levy an administrative fee as approved by the Board of Directors from time to time.
- 12.2.2 that such permission will automatically lapse and be deemed to be withdrawn upon the grantee’s rights to occupation of the Unit being terminated or expiring for any reason whatsoever or upon the owner ceasing to be a Member;
- 12.2.3 that the Owner is and remains fully paid-up in respect of all his obligations to the Association;
- 12.2.4 that such permission shall not release the owner from his obligations to the Association in respect of his membership relating to such Unit at all times;
- the said conditions prescribed by the Board of Directors in respect of the class of persons referred to in clause 12.2 above shall be no more onerous than those applying to the owner himself.

13. **LETTING AND SELLING**

- 13.1 No member shall let or otherwise part with occupation of his unit, whether temporarily or otherwise, unless he has complied with the provisions stipulated in paragraph 12 of these RULES.
- 13.2 Should a member wish to let or sell his unit through an estate agent, he shall be obliged:
- 13.2.1 to give his agent a written mandate;



- 13.2.2 to procure that such written mandate contains the following terms:
- "The agent acknowledges that he has in his possession a copy of the RULES of Port Zimbali Estate Home Owners' Association (NPC), and, for the benefit of Port Zimbali Estate Home Owners' Association (NPC), undertakes to execute the mandate according to the provisions of the said RULES",*
- 13.2.3 to submit the said mandate to the Association for its written approval prior to the commencement by the agent of the execution of his mandate – the written approval being evidenced by an Accreditation Certificate issued by the Association,
- 13.2.4 to ensure that any agent under such mandate from such member, shall at all times have a copy of such mandate and the Accreditation Certificates issued by the Association in his possession; and
- 13.2.5 to ensure that the agent complies with the provisions of the Accreditation Policy for Estate Agents as fully described in the RULES.
- 13.3 Should any member be in breach of rule 13.2 above, the Association shall have the right to restrain any agent from carrying on any selling or marketing activity within the complex on behalf of such member.
- 13.4 No member shall be entitled to transfer ownership of or any other interest in his unit without a clearance certificate being issued by the Association, by which it is certified that:
- 13.4.1 the member is not indebted to the Association in any way in respect of contributions and charges or any other amounts which the Association may, in terms of these RULES, be entitled to claim from him;
- 13.4.2 the member has arranged for the purchaser to make irrevocable provision for the payment of the Levy Stabilisation Fund contribution as contemplated in the MOI;
- 13.4.3 the written agreement between the member and the buyer has been submitted to the Association, which has satisfied itself that the required clauses referred to in 13.7.4 below, are contained in the said written agreement;
- 13.4.4 the member is not in breach of the provisions of the RULES of the Association.
- 13.5 The Association shall not be entitled to refuse to issue the clearance certificate if a member complies with the requirements in rule 13.4 above.
- 13.6 The Association and/or the Managing Agent shall be entitled to fix a reasonable fee to be charged for the issuing of all clearance certificates.
- 13.7 The member selling a unit in the complex, or an interest in such unit, shall ensure that the written agreement of sale contains the following clauses and the Deed of transfer contains the clauses set out in 13.7.5 below and ensure that:
- 13.7.1 The purchaser acknowledges that he is aware that, upon registration of the property into his name, he will be a member of the Association.



- 13.7.2 The purchaser acknowledges that he has received from the seller a copy of the RULES of the Association and, for the benefit of the Association, agrees to be bound by such rules from the date of his occupation of the property.
- 13.7.3 This agreement is subject to the suspensive condition that the seller receives a clearance certificate from the Association.
- 13.7.4 The Association has its own attorneys who either tend to the registration of transfer, or, if the seller so chooses, who act in a supervisory capacity on behalf of the Association. Should the seller therefore wish to appoint an alternative conveyancer to tend to the registration of transfer, the cost of supervision by the Association's attorneys will be for the seller's account.
- 13.7.5 The seller shall be entitled to procure that, in addition to all other conditions of title, the following conditions of title be inserted in the Deed of Transfer, in terms of which the purchaser takes title of the property:
- 13.7.5.1 *"Every owner of an erf, or owner of any sub-divisions thereof, or owner of any unit thereon shall become and shall remain a member of Port Zimbali Estate Home Owners' Association (NPC) and be subject to its Memorandum of Incorporation and its RULES, until he ceases to be an owner as aforesaid.";*
- 13.7.5.2 *"Neither the erf, nor sub-division thereof, nor any unit thereon, shall be transferred to any other person who has not bound himself to the satisfaction of Port Zimbali Estate Home Owners' Association (NPC) to become a member of the said Association.";*
- 13.7.5.3 *"The owner of the erf, or owner of any sub-divisions thereof, or any unit thereon, shall not be entitled to transfer the erf or any sub-division thereof, of any interest therein, or any unit thereon, without a clearance certificate from Port Zimbali Estate Home Owners' Association (NPC) stating that the provisions of the Memorandum of Incorporation and the RULES of the said Association have been complied with.".*
- 13.8 A copy of the generic lease agreement procured by the Association is available for members desirous to making use thereof. Members/agents are advised that while the Association has utilised its best endeavours to ensure that the generic lease agreement best caters for the needs of all of its members, that the agreement remains of a generic nature and that members should ensure that the content of the agreement best caters for their specific needs. The Association does not accept any liability for any claims, loss or damages arising from the use of the generic lease agreement by members or their tenants. Members should ensure that they have read and understood the entire content of the generic lease agreement and as such ensure that it best caters for their needs prior to making use it – amendments may be made to cater for specific needs. Members should take note of the following in respect of the generic lease agreement:
- 13.8.1 A copy of the latest RULES of the Association must be attached to the generic lease agreement.
- 13.8.2 The lease period may not be for periods shorter than 6 consecutive months in time.
- 13.8.3 Members will remain responsible for the payment of water and sewerage charges to the Association, but provision has been made in the generic lease agreement to recover this amount from the tenant.
- 13.8.4 Provision has been made in the generic lease agreement for members to recover the Tenant Clearance Certificate fee.



14. **SPECIFIC RIGHTS OF THE ASSOCIATION**

- 14.1 Members are obliged to pay the Association for additional services rendered. These additional services fall into the category of the Association being required to pay for the service on behalf of all the members of the Association, the Association then being required to recover the amounts expended on behalf of the members from the members via their levy accounts held with the Association.
- 14.2 Certain of these services pertain to the -
- 14.2.1 provision of water and sewer facilities,
- 14.2.2 usage of water and sewer, which is separately metered via water meters found on each member's private property, it being recorded that water meters are the property of the Association and that the consumption recorded on such water meters is for the account of the relevant Member, and
- 14.2.3 landscaping maintenance services.
- 14.3 The Association reserves all the specific rights as would similarly be found in the by-laws of the Local Authority or their relevant licensees for itself relating to water and sewer usage.
- 14.4 In the event of non-payment by a member of the amount pertaining to the provision and usage of water and sewer as depicted on that member's levy account, the Association has the right to reduce water provision to a trickle on the member's private property to limit its financial loss.
- 14.5 To re-instate the water supply to normal, the member must pay the amount due and outstanding for water and sewer in full and request the Association to do the physical re-instatement of the water-supply. At each instance of a re-instatement request by a member, the Association has the right to levy a water re-instatement fee on the member and in addition has the right to only re-instate the water connection once the water re-instatement fee has been paid.
- 14.6 In the event of a member being in arrears on his levy account, the Association has the specific right to remove automatic access to the member from the computerised access control system of the Association found at the gate-house on the Estate until such time as the member has made good the amount in arrears on his levy account. Re-programming of access registration will attract the normal re-programming fee as depicted in the Security Procedures and Policy of the Association for every instance re-programming is requested from the Association.
- 14.7 Breach and the imposition of penalties
- 14.7.1 Any member that contravenes or fails to comply with any provision of the RULES shall be deemed to have breached the RULES and will be subject to any penalties imposed by the Board of Directors having regard to the circumstances and which may include the imposition of penalties for each separate offence.
- 14.7.2 The Board of Directors shall, in their discretion, impose a penalty proportionate to the seriousness of the contravention.



- 14.7.3 The following procedural steps will be taken against members that do not abide by the RULES:
- 14.7.3.1 First offence – Written warning and advise of imposing a penalty;
 - 14.7.3.2 Second offence – Imposing a penalty and warning of litigation;
 - 14.7.3.3 Third offence – Imposing an increased penalty and litigation.
- 14.7.4 In the event of a breach by members of the member's household, employees, contractors, invitees, guests and tenants and the members of the tenant's household, employees, contractors, invitees and guests, the member shall be liable for the payment of any penalty imposed.
- 14.7.5 Any penalty imposed on a member, in terms of these rules, shall be a debt due and payable to the Association by the member and will be added to the monthly levy account of the member.
- 14.7.6 Should a member fail or refuse to comply with the RULES, the Association may take whatever action necessary and appropriate in the circumstances and recover from the Member any cost incurred in taking such action without prejudice to its rights to recover any fines or other penalties imposed.
- 14.8 Domicilium Citandi Et Executandi
- 14.8.1 The address of the Association constituting its domicilium citandi et executandi, shall be as is registered in terms of the Notice of Incorporation registered with the Companies and Intellectual Property Commission ("CIPC").
- 14.8.2 The domicilium citandi et executandi of each Member shall be the address of the Unit registered in the Member's name, provided that such Member shall be entitled to change the said domicilium citandi et executandi but that any new domicilium citandi et executandi selected shall be situated in the Republic of South Africa, and that the change shall only be effective upon receipt of written notice thereof by the Association.
- 14.9 Notices
- 14.9.1 For any notice or document to be delivered or published for any purpose contemplated in the Act, the Regulations, this MOI or the Rules of the Association, the provisions of Table CR3 in terms of Regulation 7, as amended in terms of this MOI, shall apply and for which purpose such notice may be delivered:
- 14.9.1.1 by fax, if the addressee has a fax number; or
 - 14.9.1.2 by electronic mail, if the addressee has an address for receiving electronic mail; or
 - 14.9.1.3 by registered post to the addressee's *domicilium citandi et executandi* or last known address; or
 - 14.9.1.4 by hand to the addressee or to any representative authorized in writing by the addressee to accept service; or
 - 14.9.1.5 by leaving the notice at the addressee's place of residence or business with a person who is apparently at least 16 years old and in charge of the premises at the time; or
 - 14.9.1.6 by leaving the notice at the addressee's place of employment with a person who is apparently at least 16 years old and apparently in authority.



- 14.9.2 A notice will be deemed to have been delivered if:
- 14.9.2.1 by fax – on the date and at the time recorded by the fax receiver, unless there is conclusive evidence that it was delivered on a different date or a different time;
 - 14.9.2.2 by electronic mail – on the date and at the time recorded by the computer used by the sender, unless there is conclusive evidence that it was delivered on a different date or at a different time;
 - 14.9.2.3 by registered post – on the 3rd (third) day following the day on which the notice or document was posted, as recorded by the Post Office, unless there is conclusive evidence that it was delivered on a different day;
 - 14.9.2.4 by hand – on the date and at the time recorded on a receipt for the delivery;
 - 14.9.2.5 by leaving the notice at the place of residence or business of the addressee – on the date and at the time recorded on a receipt for the delivery;
 - 14.9.2.6 by leaving the notice at the addressee’s place of employment – on the date and at the time recorded on a receipt for the delivery.
- 14.9.3 Any notice to be given by a Member to the Association shall be delivered to the Association by delivery of such notice to the registered address of the Association, as recorded in the records of CIPC from time to time.

15. **CONSTRUCTION and/or INSTALLATION RULES AND ACTIVITIES**

- 15.1 As the buildings/dwellings within the Estate will be constructed over a considerable time period, the following RULES, amongst others, have been formulated for the benefit of residents, namely:
- 15.1.1 The initial requirement for the commencement of any construction or installation activity within the Estate is the member being in possession of a Construction/Installation Clearance Certificate (see paragraph 15.3). Estate Management issues this certificate subject to prerequisites being met – described below. The certificate must be in possession of the Contractor or the member at all times and must be presented upon request from either Estate Management, or a Security Officer or a member of the Board of Directors or the Managing Agent. The Developer is exempt from this RULE.
 - 15.1.2 All building materials must be stored within the building site boundary. In the event of a vacant site being situated adjacent to the building site, this site may be utilised for storage purposes, but on condition the “building” member acquires the written permission from the owner of the adjacent site for this purpose and presents such written permission to Estate Management together with the application for a Construction Clearance Certificate.
 - 15.1.3 No building materials may be off-loaded onto the road or the verges.
 - 15.1.4 No advertising or sub-contractors boards will be permitted. Only the approved professional’s information board will be permitted - the Association must approve the design of the board before it is erected on the site.
 - 15.1.5 Contractor screening and securing of building site
 - 15.1.5.1 The contractor must screen the entire building site (should a vacant adjacent site be used for storage purposes as contemplated in these RULES, this vacant adjacent site will be regarded as part of the building site).



- 15.1.5.2 Screening must be erected out of green shade-netting with a minimum shade-factor of 75% (seventy five percent), which must be secured to wire strands that are attached to gum-poles. The installation must be of a sufficient quality so as to remain neat for the relevant construction period on the building site.
- 15.1.5.3 The building site must have access entrance gates, which must be locked when the building site is unattended.
- 15.1.5.4 The contractor must provide screened ablution facilities for the workmen and sub-contractors under his control.
- 15.1.5.5 The contractor must erect relevant "indemnification" and "right of admission reserved" signage at the entrance to the site.

15.2 Hours

15.2.1 Contractor activity is only permitted between the following hours, Mondays to Saturdays:

<u>Week days</u>	<u>Saturdays</u>
06:30 – 18:00	06:30 – 16:00

15.2.2 Delivery of supplies is only permitted between the following hours, Mondays to Saturdays:

<u>Week days</u>	<u>Saturdays</u>
07:30 – 17:30	07:30 – 16:00

- 15.2.3 No construction activity or delivery of supplies is to take place on Sundays and public holidays, as these days are viewed as private time for residents.
- 15.2.4 The Association will define delivery routes and delivery hours from time to time and all contractors are to obtain these restrictions from Estate Management.
- 15.2.5 Fines will be imposed by the Association on contractors and delivery vehicles that spill material en route, damage roadways and kerbing, stain road surfaces, damage any other infrastructure of the Association and generally create a nuisance within the Estate.
- 15.2.6 A copy of the Contractors' Code of Conduct and other relevant and applicable rules and regulations can be obtained from Estate Management.

15.3 Construction and/or Installation Clearance Certificate

- 15.3.1 Before any construction or installation may commence, the member and his contractor must be in possession of the relevant Clearance Certificate. The Developer and/or the Developer's Main Building Contractor is exempt from this RULE.
- 15.3.2 A member must apply to the Association for a Construction and/or Installation Clearance Certificate to be issued. The certificate will be issued by the Association once it is satisfied with the content of the application made. The application will consist of the following, namely:
 - 15.3.2.1 A duly completed and signed Application for a Construction and/or Installation Clearance Certificate (copy of the prescribed form is attached to these RULES);
 - 15.3.2.2 A copy of the approved plans as contemplated in paragraph 1.3.4 of the Architectural Rules and Guidelines;
 - 15.3.2.3 A copy of the building contract entered into between the member and the contractor and sub-contractors;

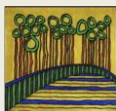

- 15.3.2.4 A copy of the contractor's paid-up reigning BUILDER'S ALL RISK INSURANCE POLICY in which it must be evident that the Association and any other member of the Association is sufficiently covered against any claim they may make as a result of losses potentially resulting from construction and installation activities to be undertaken;
- 15.3.2.5 A duly completed Contractor's Code of Conduct, signed by both the member and the contractor;
- 15.3.2.6 Receipt of the relevant access application for access forms as prescribed in the Security Policy and Procedures for contractors, subcontractors and their workers and employees;
- 15.3.2.7 Payment of the Security Deposit, if applicable. The RULES pertaining to a Security Deposit are as follows:
- 15.3.2.7.1 The member is responsible for the payment of the deposit amount;
- 15.3.2.7.2 The payment of the deposit amount is in the absolute discretion of the Board of Directors, but in any event, payable in either or both of the followings instances:
- 15.3.2.7.3.1 where the cost of the subject project is in excess of R40,000 (forty thousand Rand); and
- 15.3.2.7.3.2 where the member, in terms of these RULES, is obliged to present drawings and/or plans to the Architectural Review Committee of the Association for approval.
- 15.3.2.7.3 The Security Deposit amount is as displayed in a document named Levies, Fees, Charges and Recoveries, approved by the members in general meeting from time to time (normally at the Annual General Meeting), and published on the website of the Association (www.pze.co.za);
- 15.3.2.7.4 The Security Deposit will be utilised to make good any damaged kerbing, roadways, pavements, manhole covers and any other infrastructure of the Association once construction activities commences and is caused by the member's contractor(s).
- 15.3.2.7.5 Taking the content of this paragraph 15.3.2.7 into account, any balance remaining will be refunded to the member subject to the following conditions:
- 15.3.2.7.5.1 request by the member for Estate Management to complete a site and Estate inspection ("site inspection"), the content of which to be recorded on the relevant application form;
- 15.3.2.7.5.2 the aim of the site inspection is not to approve or ensure the quality of the work;
- 15.3.2.7.5.3 the aim of the site inspection is to ensure that –
- 15.3.2.7.5.3.1 the work performed and completed conforms to the plan submitted and approved as contemplated in the Architectural Rules and Guidelines;
- 15.3.2.7.5.3.2 the work is consistent with the Architectural Rules and Guidelines;
- 15.3.2.7.5.3.3 no damage was caused to any infrastructure of the Association, or in the event of damage having been caused, that such damage has been remedied to the satisfaction of Estate Management;
- 15.3.2.7.5.3.4 no damage was caused to the property of a neighbouring or any other member of the Association, or in the event of damage having been caused, that such damage has been remedied to the satisfaction of Estate Management;
- 15.3.2.7.5.3.5 the contractor has complied with all the provisions of the Contractor's Code of Conduct;
- 15.3.2.7.5.4 that the completed site and Estate inspection is found satisfactory.



- 15.3.3 In the event of a member/contractor having to acquire a Construction and/or Installation Clearance Certificate, such member/contractor shall make a monthly contribution to the security of the Estate for the duration such contractor will be present on the Estate to complete the relevant contract, which contribution may be waived by the Board of Directors in their sole discretion. The contribution is R1,000.00 (one thousand Rand) per month or part thereof.
- 15.3.4 The contractor's workers and/or his sub-contractors and the sub-contractor's workers are granted access to the Estate, but to a specific site in terms of the approval given by the Association via the relevant Construction and/or Installation Clearance Certificate. None of these sub-contractors and workers have access to any other part of the Estate or may not roam on any common property of the Estate and in doing so will be in breach of the RULES and will be liable for a fine or may be denied access to the Estate in the sole discretion of the Board of Directors.



**PORT ZIMBALI ESTATE HOME OWNERS'
ASSOCIATION (NPC)**

**ACCREDITATION POLICY FOR ESTATE AGENTS
(Letting and Selling)**

Section under review



PORT ZIMBALI ESTATE HOME OWNERS' ASSOCIATION (NPC)

CONDUCT RULES FOR SECURITY SERVICE PROVIDERS AND SECURITY OFFICERS

1. The high standard of the security in and on the Estate, but more importantly the objective of not only continually sustaining the high standard of the security enjoyed, but also the striving to enhance and improve on this standard, is one of the primary reasons members and/or their tenants have chosen to reside on the Estate and/or have chosen to invest in the Estate. The Security service provider shares in the responsibility with the Association and its members to achieve this objective.
2. The gate-house, which also serves as the base from where the Security service provider, in respect of Port Zimbali Estate, and their security officers operate from, serves as the primary advertisement of not only the high standard of security in and on the Estate, but also as initial advertisement to the public and the guests of the members in respect of Port Zimbali Estate.
3. Because first impressions count, **nothing less** than unquestionable, ultimately superior security services, incorporating the consistent and unwavering application of the Association's Security Policies and Procedures will be acceptable to the Association. The Security service provider appointed by the Association must irrevocably agree to this service level commitment - therefore the Association unreservedly places the responsibility on the Security service provider to ensure that –
 - 3.1 all Security Officers provided to the Association must as a minimum be –
 - 3.1.1 professional security officers holding the grading level for each shift being as mutually agreed between the Security Service Provider and the Association,
 - 3.1.2 smartly attired and conduct their security activities in a professional manner at all times,
 - 3.1.3 fully-trained, it being recorded that proof of qualifications must be handed to Estate Management for all newcomers presented to the Association at the commencement of duty,
 - 3.1.4 fluent in English and able to verbally communicate clearly, whether face to face or over the telephone, and be able to efficiently write down any instructions that need to be recorded.
 - 3.2 the all-round performance and required competence level of the security officers so provided must be constantly monitored and evaluated by the Security service provider; and that any refresher training required be immediately undertaken; with the outcome of all monitoring and evaluation and subsequent refresher training to be formally recorded with the Association.
 - 3.3 with the assistance of Estate Management, the security officers so provided are trained to have a complete and comprehensive understanding of the Security Policies and Procedures of the Association;



- 3.4 with the assistance of Estate Management, the security officers so provided are trained to have a basic FIRST-AID knowledge;
 - 3.5 with the assistance of Estate Management, the security officers so provided are provided with and comprehensively trained in EMERGENCY PROTOCOLS that need to be followed when such relevant situations arise – these situations include of instances of medical necessity, criminal activity, fire alarms, life-threatening situations and police assistance required;
 - 3.6 the security officers so provided consistently and unwaveringly apply the Security Policies and Procedures of the Association and react according to EMERGENCY PROTOCOLS when required from them;
 - 3.7 any one or more of the security officers so provided be removed and replaced with suitable security officers at every instance of such a request by the Association;
 - 3.8 the security equipment provided for the benefit of the security officers, Security service provider and the Association, whether owned by the Association or the Security service provider, namely: computers, radios, bloodhound system, panic button, radio connectivity and communication with the control room of the Security service provider and any security equipment that may be installed in the future by the Association or the Security service provider, is in full working condition at all times;
 - 3.9 regular visits to the Estate are made by supervisory staff (i.e. the Inspector) of the Security service provider with a view to driving through the Estate to provide additional security visibility to and on the Estate, it being recorded that such staff must be registered for access to the Estate. The biometric devices must be used when accessing the Estate so as to maintain a record of such visits by such staff;
 - 3.10 that the security officers so provided ensure that the gate-house and its surrounds are neat, clean, tidy, free from litter and professionally presentable at all times;
 - 3.11 regular visits are made to the Estate by the Compliance Officer of the Security service provider to not only monitor and assess, but also to assist security officers, it being recorded that such staff must be registered for access to the Estate. The biometric devices must be used when accessing the Estate so as to maintain a record of such visits by such staff; and
 - 3.12 regular monthly visits are held by an official of the Security service provider of Managerial standing with Estate Management to create a continued and stable forum during which both parties can assess all security aspects of the Estate with a view to, amongst other items, improving and enhancing the security on Port Zimbali Estate, it being recorded that such staff must be registered for access to the Estate. The biometric devices must be used when accessing the Estate so as to maintain a record of such visits by such staff.
4. The Security service provider takes possession and occupation of the gate-house and relevant infrastructure on a similar basis as a tenant takes occupation of the property from a landlord, implying that the Security service provider is responsible for damages to the gate-house and relevant infrastructure – normal wear-and-tear excluded.



PORT ZIMBALI ESTATE HOME OWNERS' ASSOCIATION (NPC)

ARCHITECTURAL RULES AND GUIDELINES

1. OBJECTIVES

1.1 Another of the main objectives of the Association is to ensure that the overall development is in unison to create a balanced and compatible lifestyle for all residents by encouraging individual creativity while fostering a unity of material and finishes. The powers given to the Directors by the Memorandum of Incorporation to create and implement RULES, is for the protection of this objective on the Estate.

1.2 These guidelines, in addition to the above, aim to ensure that all building work undertaken on a stand in the Estate will comply with the National Building Regulations as regulated by the Local Authorities and the Port Zimbali Town Planning Scheme.

1.3 Architectural Review Committee

1.3.1 The Directors will establish a committee, consisting of at least one qualified and duly registered Architect and two Directors from the Board of Directors.

1.3.2 The committee will be known as the Architectural Review Committee ("ARC").

1.3.3 The ARC's responsibilities are all encompassing in respect of considering and assessing presentations made by members or their agents. The ARC has the right of either approving or declining a presentation, whichever the case might be, and if applicable, without providing reasons therefore, but subject to decisions being consistent and equitable in view of achieving the objectives described in these RULES.

1.3.4 **Presentation to the ARC is required under the following conditions:**

1.3.4.1 Dwellings

1.3.4.1.1 New dwellings.

1.3.4.1.2 Renovations undertaken to the interior of an existing dwelling does not require referral to the ARC.

1.3.4.1.3 Renovations and additions to existing dwellings, exterior paving or hard surfaces and other built/installed structures, including instances where –

1.3.4.1.3.1 work of any nature is undertaken that will visibly change the current exterior structures of the home, garden walls, fences, wooden screening, paving and pool surrounds; and



1.3.4.1.3.2 existing doors and/or windows are removed from the exterior walls of a building or installing new doors and/or windows in exterior walls of a building, as this will visibly change the exterior of a building.

1.3.4.2 Landscaping

1.3.4.2.1 New dwellings and landscape installations.

1.3.4.2.2 When work of any nature is undertaken that will either visibly change the current landscape of the property or such work will cause the member to deviate from an existing landscaping plan.

1.3.4.2.3 Where larger specie vegetation (such as trees, larger shrubs and plants) found on the boundaries between two properties that clearly fulfils the role of providing privacy for neighbouring members.

1.3.4.2.4 Where vegetation (such as shrubs, plants, lawns and ground covers) not on the boundary and clearly not fulfilling a privacy role on the property does not require referral to the ARC and may be replaced provided that such replacements are listed in the Plant List of the Association and provided that there will not be deviated from the existing landscape plan.

1.3.5 **The ARC Process**

1.3.5.1 Estate Management, as the custodian of ARC affairs, will fulfil the complete managerial and secretarial roles of the ARC, which includes the following:

1.3.5.1.1 Receiving applications from members and ensuring that these are complete for placing on the agenda for consideration at the forthcoming ARC meeting.

1.3.5.1.2 Publishing agendas, minutes and lists of interim ARC decisions.

1.3.5.1.3 Generating correspondence to members depicting decisions taken and conditions set by the ARC.

1.3.5.1.4 Monitoring the progress of all projects approved by the ARC, specifically taking into account the content of the original presentation provided to the ARC, the conditions set by the ARC during the approval process and reporting back to the ARC at every monthly meeting on incomplete projects.

1.3.5.1.5 Signing off on projects that have been completed to the satisfaction of the ARC.

1.3.5.2 The ARC will meet once a month.

1.3.5.3 Insofar as the approval of the designs of New Developments and Major Alterations and Additions ("High Impact" projects). The following is applicable –

1.3.5.3.1 To assist members to not incur unnecessary costs, they are invited and encouraged to make presentation to the ARC at the design stage of their project.

1.3.5.3.2 Once mutual agreement by the member and the ARC is achieved with the design of the project final plans must be presented to the ARC for approval.

1.3.5.3.3 The fee for tabling items for approval at the ARC is applicable and payable.

1.3.5.4 Uncertainty as to whether ARC referral is required

1.3.5.4.1 Members that have embarked on a project without referring the details of such project to the ARC, such members holding the opinion that referral is not necessary, are obliged to provide details of the project that is underway to Estate Management – it is the responsibility of Estate Management, as custodian of ARC matters, to report on such matters to the ARC.



- 1.3.5.4.2 If uncertainty exists as to whether a project can be regarded as one that does not require ARC approval, members should communicate fully with Estate Management with regard to the envisaged project via email. After investigating the request, Estate Management will respond to the member via reply email as follows:
- 1.3.5.4.2.1 If the envisaged project is found to be "Low Impact" in nature, the original request will be ratified, where after the member may proceed with the envisaged project.
- 1.3.5.4.2.2 If the envisaged project is not found to be "Low Impact" in nature, the member must make formal application to the ARC.
- 1.3.5.5 All applications by members must be submitted in writing, and once satisfactorily complete, they will be tabled for presentation to the ARC at the next ARC meeting. While an email application is acceptable (in the case of "Low Impact" Projects), the ARC reserves the right to insist that the member provides a completed "Application for a CONSTRUCTION and/or INSTALLATION CERTIFICATE" which can be found on the website of the Association (www.pze.co.za). Full detail remains a requirement, and where applicable, such application must be accompanied by plans, drawings and/or sketches.
- 1.3.5.6 Decision exceptions
- 1.3.5.6.1 An individual, in his capacity as a member of the ARC, does not have the authority to make a decision in such individual capacity, and as a result, no on the spot decisions can be made.
- 1.3.5.6.2 An exception will be made –
- 1.3.5.6.2.1 When the application is accompanied by a detailed written explanation justifying WHY such an exception is being requested.
- 1.3.5.6.2.2 If the exception is justified, then Estate Management will utilise a Round Robin mechanism to obtain a unanimous decision from all the ARC members.
- 1.3.5.6.2.3 Where an exception relates to the removal of an "Offending Tree", the member may proceed with the removal of such tree, but subject to the "Offending Tree Rules" contained herein.
- 1.3.5.7 Offending Tree Rules
- 1.3.5.7.1 The Association has identified the following trees as Offending Trees:
- 1.3.5.7.1.1 Coral
- 1.3.5.7.1.2 Silver Leaf
- 1.3.5.7.1.3 Pigeon Wood
- 1.3.5.7.2 Estate Management is empowered to grant approval to the member for the removal of Offending Trees, and merely needs to inform the ARC at the next meeting, unless such trees provide screening and privacy between neighbours.
- 1.3.5.7.3 The following conditions apply to the removal of Offending Trees, namely:
- 1.3.5.7.3.1 Offending Trees found on road verges
- 1.3.5.7.3.1.1 The cost of removal will be for the member,
- 1.3.5.7.3.1.2 The Association reserves the right to request a member to plant a replacement tree at the cost of the member, and



-
- 1.3.5.7.3.1.3 If in the sole discretion of the Association the tree is potentially dangerous to person or property, the Association will bear the cost for its removal, and if required, the member will bear the cost of a replacement tree.
- 1.3.5.7.3.2 Offending Trees found on boundaries between member properties
- 1.3.5.7.3.2.1 If applicable, the neighbouring members must agree to the removal of an offending tree, especially when the subject tree services a privacy and screening purposes,
- 1.3.5.7.3.2.2 The cost of removal will be for the requesting member, unless the requesting member has made a different arrangement with the neighbouring member, in which instance such arrangement must be documented, signed by both members and the signed document must accompany the tree removal request,
- 1.3.5.7.3.2.3 The requesting member may be requested to plant a replacement tree, and
- 1.3.5.7.3.2.4 The requesting member must provide the Association with the written agreement, signed by both affected members owning the relevant neighbouring properties.
- 1.3.5.8 Other Trees – Application must be submitted to the ARC for approval.
- 1.3.5.9 ARC Decisions
- 1.3.5.9.1 Member’s applications will be placed on the Agenda for next meeting by Estate Management, but only if the presentations is complete in all aspects.
- 1.3.5.9.2 Once the application is approved by the ARC the member will be informed in writing on an ARC letterhead specifying the conditions, if any.
- 1.3.5.9.3 If the application is declined by the ARC the member will be informed in writing on an ARC letterhead listing the reasons why it was declined.
- 1.3.6 Presentations must be made for the following (the RULE being recorded that the member must be in possession of a written approval of the presentation prior to any commencement of construction and/or installation activities), namely:
- 1.3.6.1 Building plans for a new dwelling;
- 1.3.6.2 Building plans for any alteration and/or addition to an existing dwelling;
- 1.3.6.3 Building plans for any additional building structure on a private property;
- 1.3.6.4 Building plans for the partial or complete enclosure any area of an existing dwelling;
- 1.3.6.5 Deviations from building plans previously approved;
- 1.3.6.6 Landscaping plans for new landscape installations or landscaping plans for the complete overhaul of an existing landscape or to deviate from previously approved landscaping plans;
- 1.3.6.7 Building plans for the installation of swimming pools, incorporating swimming pool safety measures as required by the Local Authorities;
- 1.3.6.8 Building plans for the installation any awning, patio, carport, gazebo, deck or any other structure, irrespective of whether or not it is a requirement to present plans to the Local Authorities;
- 1.3.6.9 Plans for the installation of air-conditioning units, depicting the steps that are to be taken to visually impede the compressor units in the event of these being visible from any street within the Estate, or from the MR398 or from any neighbouring member’s property – including time lines anticipated to achieve the visual impediment;



- 1.3.6.10 Plans for the installation of solar heating systems for swimming pools, depicting the steps that are to be taken to visually impede the solar panels and/or solar systems in the event of these being visible from any street within the Estate, or from the MR398 or from any neighbouring member's property – including time lines anticipated to achieve the visual impediment;
- 1.3.6.11 Plans for the installation of solar geyser systems, depicting the steps that are to be taken to visually impede the solar systems in the event of these being visible from any street within the Estate, or from the MR398 or from any neighbouring member's property – including time lines anticipated to achieve the visual impediment;
- 1.3.6.12 Plans for the installation of garden fencing, screening or garden safety balustrades, together with, if in the discretion of the ARC it is required, the steps that are to be taken to visually impede the fencing and/or screening in the event of these being visible from any street within the Estate, or from the MR398 or from any neighbouring member's property – including time lines anticipated to achieve the visual impediment;
- 1.3.6.13 Plans for the enclosure of existing patios;
- 1.3.6.14 Presentations for the use of fuel driven power generators and, if applicable, plans for the installation of enclosures thereof, together with, if in the discretion of the ARC it is required, the steps that are to be taken to visually impede the enclosures in the event of these being visible from any street within the Estate, or from the MR398 or from any neighbouring member's property – including time lines anticipated to achieve the visual impediment;
- 1.3.6.15 Presentations for the installation of water harvesting/storage tanks and, if applicable, plans for the installation of enclosures thereof, together with, if in the discretion of the ARC it is required, the steps that are to be taken to visually impede the tanks in the event of these being visible from any street within the Estate, or from the MR398 or from any neighbouring member's property – including time lines anticipated to achieve the visual impediment;
- 1.3.6.16 Presentation for the installation of fibre glass garage doors.
- 1.3.7 Prior to making a presentation to the ARC, any member/owner is obliged to obtain, in writing, agreement from his/her neighbour should the work anticipated in any way have a visual impact on such neighbour.
- 1.3.8 The Association has the right to set and charge a member a Scrutiny Fee for assessing and considering every presentation submitted.
- 1.3.9 Once approved by the ARC, building, landscaping and/or deviation plans must be submitted to the Local Authorities for approval. It is the member's responsibility to make these particular submissions (if requested by the member, the ARC can provide guidance in this regard), it being recorded that the cost hereof will be for the member's account.
- 1.3.10 No deviation from any plan or drawing submitted/presented to and approved by the ARC will be permitted. Revised plans/drawings will have to be re-submitted/presented to and accepted by the ARC before any construction/installation work may commence. In the discretion of the Board of Directors, an additional fee may be levied when submitting revised plans/drawings.



1.4 Building commencement limitations

NO building commencement time constraint

1.4.1 Building and construction commencement limitations serve to minimise inconvenience to members resident on the Estate. While building and construction activities are identified as the main source of inconvenience, undeveloped properties, if suitably regularised, cause little to no inconvenience at all. Therefore, the Association places NO building commencement time constraint on a member when the member acquires an undeveloped property on the Estate. This RULE applies to acquisitions either from the Developer or from a current member of the Association. The NO building commencement time constraint is subject to the following, namely:

1.4.1.1 The owners of undeveloped properties are obliged to do basic landscape maintenance to their properties ensuring such properties are kept neat, free from litter, debris and foreign objects and free from alien growth and vegetation. Field grasses must not be removed. The Eucalyptus trees found on such properties are exempt from requiring removal for as long as building activities have not commenced on the property.

1.4.1.2 For this basic landscape maintenance purpose, the owner is obliged to utilise the service provided by the landscape service provider appointed by the Association.

1.4.1.3 The basic landscape maintenance charge will be 50% of the normal Landscaping Maintenance Charge applicable to developed sites, as published from time to time, and will be charged on a monthly basis; the service will however only take place twice a month. Such charge will be recovered via the member's monthly levy account.

1.4.1.4 The Developer is exempt from this RULE, except in instances where a property owned by the Developer is directly adjacent to a property owned by a member of the Association, in which case the Developer will be obliged to do basic maintenance to such property ensuring the property is kept neat, free from litter, debris and foreign objects and free from alien growth and vegetation.

1.4.1.5 The owners of undeveloped properties are not obliged to submit building plans for construction to the Local Authorities during the period of non-development.

Building and construction completion time constraints

1.4.2 In order to reduce inconvenience to neighbours as well as unsightliness, once building and construction activities do commence, the activities should proceed without lengthy interruptions. The following applies to building and construction completion, namely:

1.4.2.1 Regarding new building projects on undeveloped properties - building and construction activities and must be completed within 20 (twenty) months, exclusive of the builder's holiday period during December/January every year (the "Construction Period"), from the Date of Commencement.

1.4.2.2 Regarding renovations and/or additions to existing dwellings - building and construction activities and must be completed within 6 (six) months, inclusive of the builder's holiday period during December/January every year (the "Construction Period"), from the Date of Commencement.

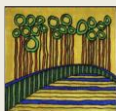

- 1.4.2.3 The ARC will issue a certificate certifying the Date of Commencement of each specific project.
- 1.4.2.4 The ARC, in its sole discretion, may require phased construction, the aim of which is to ensure that the end of each phase will be aesthetically acceptable to the Association.
- 1.4.2.5 In terms of the Architectural Rules and Guidelines section of the RULES of the Association, the ARC approves all building projects. The ARC therefore has the right, in its sole discretion, to increase or decrease the length of the Construction Period if, based on the specifications and scope of work of the building project in question, it deems a variation fitting.
- 1.4.3 The Association reserves the right to implement punitive measures against any member that fails to meet the conditions for the NO building commencement time constraints (paragraph 1.4.1 above) and the building and construction completion time constraints (paragraph 1.4.2 above). The maximum punitive measure is a monthly punitive levy of six times the normal monthly levy, the variation and application thereof being in the sole discretion of the Board of Directors. The Developer and members contracted to the Developer for building of dwellings are exempt from this condition.
- 1.4.4 The additional funds the Association may receive, as a result of the implementation of the punitive measures described in paragraph 1.4.3 above, will be utilised to pay for the increased costs the Association may incur to improve the living conditions of the members who are resident on the Estate and can include expenses such as increased security requirements and landscaping improvements and maintenance.

2. **TOWN PLANNING CONTROLS**

2.1 All stands

- 2.1.1 Coverage is limited to 35% (thirty five percent) of the size and extent of each particular stand.
- 2.1.2 No dwelling shall be smaller than 150m² (square meters), excluding outbuildings, verandas patios and garages.
- 2.1.3 Only one or two storey dwellings are allowed, the maximum height of each storey measured from finished floor level to ceiling height being 3,5 meters (three comma five meters). Should the height of a storey exceed this distance, the subject storey will be deemed to be two storeys.
- 2.1.4 Height restrictions and cut and fill must be applied on the following basis:
- 2.1.4.1 Where the gradient of a stand measured from the highest point of the highest boundary of the stand to the lowest point of the opposite boundary of the stand is in **excess** of 4 meters (four), cut and fill must be kept to a minimum, and the **following height restriction will prevail**: where dwellings are accessed from street level, this street level being along the highest boundary of the stand in question, the height of the highest point of the roof of the dwelling from such street level may not exceed 6 meters (six);

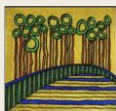

2.1.4.2 Where the gradient of a stand measured from the highest point of the highest boundary of the stand to the lowest point of the opposite boundary of the stand is **less than** 4 meters (four), whether the gradient falls in the same direction as the street or whether the gradient falls away from or toward the street, **Cut and Fill** must be applied as prescribed by the ARC taking the design of the dwelling into consideration, but subject to a **maximum height restriction** of 8 meters (eight) measured from the highest point of the roof to the lowest finished floor level.

2.1.4.3 Basements are allowed as a third level subject to –

2.1.4.3.1 The height of the entire structure not exceeding 10 meters (ten), measured from the finished floor level of the lowest habitable area to the highest roof point, and

2.1.4.3.2 The basement not being of habitable nature, but for the specific use for garage, storage or parking space.

2.1.4.4 The ARC, upon receipt of building plans submitted to it for acceptance, reserves the right to impose additional height and cut and fill restrictions on a member if it is deemed necessary.

2.2 Rezoning, sub-division and consolidation of stands

2.2.1 All and any rezoning application to change the current zoning of any of the stands is strictly prohibited.

2.2.2 Members may not subdivide their stands.

2.2.3 The Developer is exempt from this condition and may from time to time apply to rezone stands on condition that it is for residential use only and on condition that the number of sites so applied for may not exceed 6 (six).

2.2.4 The Developer may consolidate the stands referred to in 2.2.3 above into 1 (ONE) or more stands if it so chooses.

2.2.5 The Developer may sub-divide the stand(s) referred to in 2.2.4 above subject to such post sub-divided stands not being smaller than 600m² (square meters) (six hundred).

3. BUILDING LINES

3.1 The following building lines are applicable:

3.1.1 Street boundary: 5.00 meters

3.1.2 Side and rear boundaries: 2.00 meters

3.1.3 Other boundaries

3.1.3.1 MR398 (M4) boundary: 7.50 meters

3.1.3.2 Zimbali and Seaward boundaries: 6.00 meters

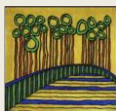

- 3.2 The ARC, upon receipt of a written application providing a motivation, will consider the relaxation of building lines. This matter may be discussed with the ARC before final plans are prepared for submission.
- 3.3 Relaxation of a building line along a boundary between two member's properties will be subject to the requesting member acquiring and providing the affected member's written consent to the relaxation requested and subject to the potential constraints resulting from servitudes registered in favour of the Association.
- 3.4 The ARC, upon receipt of building plans submitted to it for acceptance, reserves the right to impose additional building line restrictions on a member if it is deemed necessary.

4. **TREATMENT OF STAND BOUNDARIES**

- 4.1 No boundary walls or fences of any nature are allowed, unless such walls or fences –
- 4.1.1 fulfil the role of enclosing swimming pools (according to SANS 10400, edition 3, 2014 and as amended from time to time) as required by the Local Authorities;
- 4.1.2 fulfil the role of enclosing free roaming areas for pets;
- 4.1.3 fulfil the role of screening washing lines, kitchen entrances and staff quarter entrances;
- 4.1.4 fulfil the role of creating safety barriers to areas where stand gradients are regarded as being unsafe.
- 4.2 The following RULES apply to the use of walls, namely:
- 4.2.1 The total length of such boundary walls or fences is limited to 50% (fifty percent) of the perimeter of the stand when such walls are placed on the boundary of a stand;
- 4.2.2 The height of such walls is limited to 1,8 meters (one comma eight meters);
- 4.2.3 The walls must be painted plastered brick walls;
- 4.2.4 The length of the walls used for the screening of washing lines, kitchen entrances and staff quarter entrances, when placed on boundaries are to be included in the 50% (fifty percent) limitation described in 4.2.1 above - the height of the walls used for the screening of washing lines, kitchen entrances and staff quarter entrances must in any event be at least 2,1 meters (two comma one meters) high;
- 4.2.5 For privacy purposes, 50% (fifty percent) of the fences that must be erected at pools according to SANS 10400 (edition 3, 2014 and as amended from time to time) standards for pool safety purposes, may be painted plastered brick walls;
- 4.2.6 The walls to be used must be indicated accordingly on the plans submitted for approval to the ARC.
- 4.3 All other enclosures a member may require must be fences.



4.4 All fences must be landscaped to blend with the other landscape on the Estate, as described in more detail in the paragraph dealing with Landscaping in the Community Participation Rules section of these RULES.

4.5 The type of fencing approved by the Association is described in detail later in these guidelines.

5. **BUILDING DESIGN GUIDELINES**

5.1 All drawings submitted for approval to the ARC are to be prepared by a registered architect. The standard of work of the latter must be acceptable to the ARC. The information required as contained in these guidelines must be included on/with the plans submitted to the ARC for approval.

5.2 Before submitting plans to the local authority, the Association and ZEMA must approve the plans. It is the responsibility of the owner to obtain the approval of the Association, ZEMA and the approval of the local authority before any building work will be permitted. In the discretion of the Association, a scrutiny and review fee will be charged, which amount will be payable to the Association before the plans are approved.

5.3 Specific design considerations

5.3.1 Having regard for the privacy of surrounding properties, windows and balconies, especially in the instance of double storey dwellings, should not overlook the living areas of surrounding properties. To relax this RULE, the requesting member must provide the ARC with affected member's written consent to the relaxation requested.

5.3.2 No staff accommodation will be permitted closer to the street than the main house unless contained under the same roof. Kitchen yards, drying yards and staff facilities are to be screened and should open onto enclosed areas. Washing lines are to be indicated on the drawings. Washing lines and washing troughs must at all times be obscured – whether empty or loaded.

5.3.3 Outbuildings and future additions are to match the main building in all respects.

5.3.4 All plans are to indicate a minimum of two enclosed garages, which must be built in conjunction with the initial main house. Every unit must have a minimum of 2 (two) parking areas for guests on the private property – garages excluded.

5.3.5 500mm (five hundred millimetres) contours that indicate the natural slope of the ground must be shown on the site plan and the natural slope must be indicated on elevation drawings showing the floor levels relative to the natural slope.

5.3.6 No flat-roofed or shade-net or lean-to type carports will be permitted. Carports are to be designed as an integral part of the main house and to match in all respects.

5.3.7 All plumbing and sewer pipes must be installed in ducts or they must be concealed in such a manner that they are not visible from any street frontage or neighbouring property. Details hereof are required on the plans.



- 5.3.8 All driveways, including the relevant verge, are to be completely paved to a maximum width of 6 (six) meters – all paving work is for the account of the member. Finishes to driveways and walkways are to be indicated on the drawings, and the extent of driveways at the street boundary is to be shown. In the event of two driveways being envisaged from the same street frontage, the maximum combined width of both is 7 (seven) meters, subject to a minimum of a 5 (five) meter landscaped area between the driveways.
- 5.3.9 Air-conditioner units should be installed on ground level, out of the normal line of sight and in positions so as to be obscured by either garden walls or landscaping. Where this is not possible, wooden screens as approved in these RULES, must be used to obscure the units.
- 5.3.10 Cabling and trunking, such as normally used with satellite dish and air-conditioning installations, may not be visible from the streets and or neighbouring properties and should be addressed during the design process so as to achieve seamless concealment. In the event of post-initial construction installations these must be painted in the same shade as the dwelling in question.
- 5.3.11 Houses built on the visual slopes of the Estate will require special attention to reduce the interruption to the horizon line and any other visual impact. This will have to be achieved by, amongst others, additional landscaping and a sensitive approach to the scale and proportions of the buildings.
- 5.3.12 Elevation treatment of all buildings must conform to good architecture so as not to interfere with or detract from the general appearance of the neighbourhood of the Estate.
- 5.3.13 Only approved building materials and finishes are allowed in the construction of any structure on the Estate.

6. **APPROVED BUILDING MATERIALS**

The building materials detailed below must be specified clearly and in detail on plans/drawings, including colour specifications, it being recorded that colours must harmoniously match building finishes.

- 6.1 Roof covering - Clay tiles in shades of terracotta.
- 6.2 Gutters and down-pipes – Chroma-deck and pre-painted aluminium sheet metal.
- 6.3 Walls
- 6.3.1 External masonry walls to houses shall be 190mm thick with a plastered and painted finish.
- 6.3.2 The ARC must approve any other materials contemplated for use and, if required, samples must be submitted before any work is started.
- 6.3.3 No gable walls are allowed, unless required for architectural and aesthetic purposes.
- 6.4 Window frames – Aluminium
- 6.5 Door frames – Aluminium for external frames and aluminium or treated timber for interior frames.



6.6 Garage doors

6.6.1 Panelled treated timber is preferred;

6.6.2 Fibreglass and Aluminium doors are allowed. Should the colour and finish not be "Timber Look a-like", the colour of the garage doors must match the colour of the aluminium window and door frames of the dwelling in question.

6.7 Fencing

6.7.1 The Association has approved two types of fencing for use on the Estate. As from date of implementation of these RULES, either of these two types may be utilised. Estate Management will provide drawings or schematics of the fences on request by a member. Samples are available for viewing by making the necessary arrangements with Estate Management.

6.7.1.1 Ferro Art Pool And Garden Fencing - "Flat Top" fencing

6.7.1.1.1 The installed height is 1.2 meters high and the gap between the vertical bars is 10cm. This is the SABS recommendation. See graphic below.

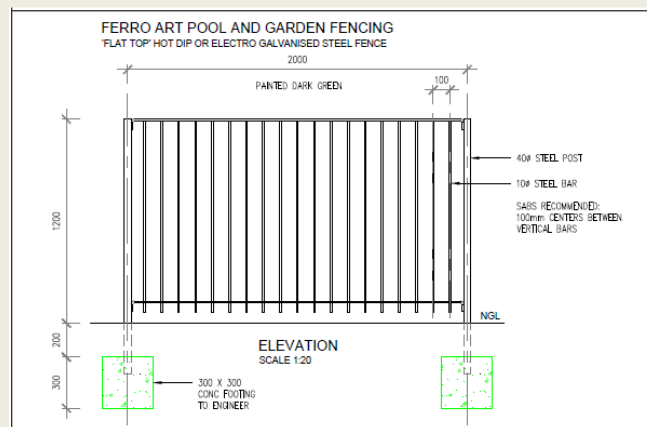

6.7.1.1.2 Ferro Art has a unique self-closing, self-latching and self-locking Safety Gate.

6.7.1.1.3 Their fence is fully Hot Dip or Electro Galvanised ensuring a rust free fence for at least five years. Minimal maintenance will ensure many years of corrosion prevention.

6.7.1.1.4 Their standard painted colours are Dark Green and White, but only the Dark Green may be used.



6.7.1.2 BetaFence – Nylofor medium with post type BetaFix

6.7.1.2.1 The fence consists of heavy welded mesh panels (NYLOFOR® 3-M), with horizontal reinforcements, made from galvanized wire, electrically welded and subsequently PVC coated. See graphic below.

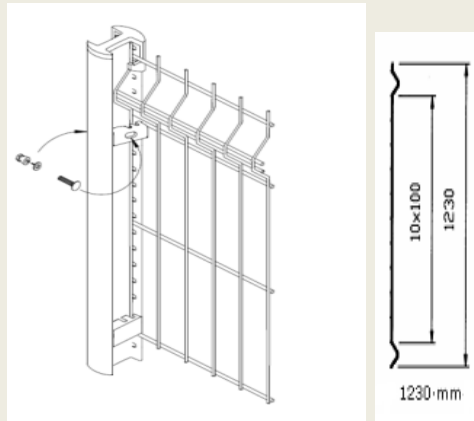

6.7.1.2.2 Specifications are as follows:

6.7.1.2.2.1 The vertical wires have barbs of 30 mm at one side of the panel (barbs at top or at bottom).

6.7.1.2.2.2 Panels of 3000 mm width.

6.7.1.2.2.3 Mesh size: 200 x 50 mm, measured from centre to centre wire.

6.7.1.2.2.4 Size of reinforcing mesh: 100 x 50 mm.

6.7.1.2.2.5 Wire diameter: 4.35 mm

6.7.1.2.3 The wire is galvanised, resistance welded and plastic coated with maximum adhesion.

6.7.1.2.4 The panels are fixed laterally onto the posts and secured with anti-vandal metal security fixators. The H-shape welded tubular posts (70 x 44 mm) are galvanised and PVC coated and supplied complete with a polyamide cap and accessories.

6.7.1.2.5 Approved colour: Green (Code: RAL 6005)

6.7.2 Where members already have different fences, these may remain in place subject to the following conditions:

6.7.2.1 The fences must be landscaped with relevant plants so as to visually impede the fencing in the event of these being visible from any street within the Estate, or from the MR398 or from any neighbouring member's property; and

6.7.2.2 Fences must be replaced, whenever applicable, with the approved fencing.



6.8 Screening

6.8.1 Screening may only be constructed out of BALU timber and be of the design as depicted in the graphic below.

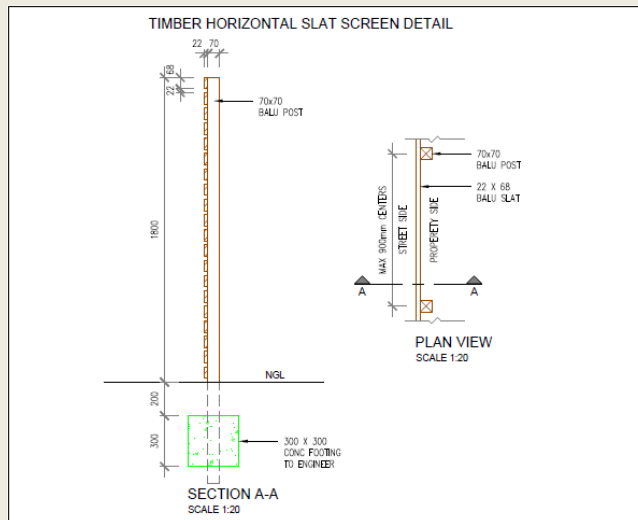

6.8.2 Where members already have different screens, these may remain in place subject to the following conditions:

6.8.2.1 The screens must be landscaped with relevant plants so as to visually impede the screening in the event of these being visible from any street within the Estate, or from the MR398 or from any neighbouring member's property; and

6.8.2.2 Screens must be replaced, whenever applicable, with the approved screening.

6.9 Paving – Clay or naturally coloured concrete pavers

6.10 Exposed concrete form-work

6.11 Solar panels and solar geysers

6.11.1 The installation of solar panels must be such that they are attached to the roof in a manner that -

6.11.1.1 the panels follow the exact pitch ("fall") of the roof for the full extent (length and breadth) of the panels;

6.11.1.2 the panels are elevated by no more than 50mm above the roof tiles and the "thickness" of the solar panel to be no more than 100mm;

6.11.1.3 in the event of more than one panel being installed, while the panels may be installed on more than one section of roof selected/approved, that **all** the panels are installed –

6.11.1.3.1 at the same height above the roof tiles, and

6.11.1.3.2 that they "line-up" with each other.

6.11.2 The choice of the section of the roof identified for the installation of the solar panels is governed by the section being least visible to the other members.



-
- 6.11.3 The use of solar geysers that have a water reservoir attached directly to the solar panel are specifically forbidden. Water reservoirs must be accommodated, either inside the roof cavity, or within the dwelling structure so as to not be visible from the outside.
- 6.11.4 Members considering solar panels are obliged to follow the Association's approval process set out herein, the cost of which will be for their account, namely:
- 6.11.4.1 Written application must be made to the Association, such application together with its attachments to be submitted in duplicate;
- 6.11.4.2 The application must include a formal "roof plan" drawing of their dwelling, the drawing indicating the position planned for the solar panels;
- 6.11.4.3 The application must include a site-plan of their own and of all surrounding dwellings, such site-plan intended to show dwellings in direct proximity to the application dwelling and the potential visual impact such a solar panel installation will have on the proximity dwellings (reference to "proximity dwelling" as contained in this notification includes undeveloped proximity stands);
- 6.11.4.4 The site-plan must, in addition, contain the approval of the owners of the proximity dwellings – such approval being visible by virtue of such proximity dwelling owner's signature on the stand of the proximity dwelling schematically shown on site-plan; and
- 6.11.4.5 The application must include a list of dimensions and specifications of the proposed solar panels to be installed.
- 6.12 Permanent installation of fuel driven power generators ("FDP Generator")
- 6.12.1 The minimum specifications for permanently installed FDP Generators are as follows, it being recorded that it is the member's responsibility to provide the Association with formal documentation from the supplier/manufacture depicting the specifications of the FDP Generator to be installed, namely:
- 6.12.1.1 Noise level - must not exceed 80 dBA @ 7 meters;
- 6.12.1.2 Power delivery - 8 to 9 Kva with 5 Kva Duty Cycle, it being recorded that generators with lesser power delivery would not justify the cost of a permanent installation.
- 6.12.2 FDP Generators must be housed in a Noise Containment Unit (a "NCU"), which must reduce the noise level to 30 dBA @ 7 meters.
- 6.12.3 Members considering the permanent installation of a FDP Generator are obliged to follow the Association's approval process set out herein, the cost of which will be for their account, namely:
- 6.12.3.1 Written application must be made to the Association;
- 6.12.3.2 The application must include a formal plan ("drawing") of the NCU;
- 6.12.3.3 The application must include a site-plan of their own and of all surrounding dwellings ("proximity dwelling"), such site-plan intended to show the positioning of the NCU as well as dwellings in direct proximity to the application dwelling and the potential noise impact such a FDP Generator will have on the proximity dwellings (reference to "proximity dwelling" as contained in this notification includes undeveloped "proximity stands");
- 6.12.3.4 The site-plan must, in addition, contain the approval of the owners of the proximity dwellings – such approval being visible by virtue of such proximity dwelling owner's signature on the stand of the proximity dwelling schematically shown on site-plan;
- 6.12.3.5 The application must include a list of dimensions and specifications of the proposed NCU of the FDP Generator to be installed, including the detailed specifications of the FDP Generator itself;



- 6.12.4 Operation of the FDP Generator is not allowed before 06:30 or after 21:00 on any given day.
- 6.12.5 To ensure continued satisfactory architectural and landscape aesthetics on the Estate, the Association reserves the right to implement additional conditions pertaining to the enclosure of the NCU – such enclosures may need to be screened by the introduction of shrubbery and/or wooden screening in accordance with the screening detailed in paragraph 6.8 of these guidelines.
- 6.13 Installation of water storage tanks (“WS Tanks”)
- 6.13.1 The Association encourages the harvesting of rain water for irrigation purposes. Grey water can also be purchased for this purpose. In order for a member to make use of the mentioned water, the installation of a WS Tank on the property of a member will be required.
- 6.13.2 WS Tanks can either be installed above the ground or below the ground. The Association recommends the installation of WS Tanks below the ground as this solves aesthetic issues and is more conducive to harvesting rain water.
- 6.13.3 All WS Tanks must be supplied and installed with a surplus water overflow. To negate the risk of erosion, surplus water harvested must be piped via the overflow to approved soakaways in accordance with engineer’s specification.
- 6.13.4 Installation above the ground
- 6.13.4.1 Should a member elect to install a WS Tank above the ground such WS Tank must be placed in the unit’s service yard and the height of the tank must be 100mm lower than height of the service yards walls.
- 6.13.4.2 The colour of the WS Tank must naturally match the exterior paint colour of the house in question.
- 6.13.4.3 A member may place a WS Tank outside the unit’s service yard; but should the WS Tank be visible from any street from within the Estate, or from the MR398 or from any neighbouring member’s property, to ensure continued satisfactory architectural and landscape aesthetics on the Estate, the Association reserves the right to implement additional conditions pertaining to the enclosure of the WS Tank – such WS Tank may need to be screened by the introduction of shrubbery and/or wooden screening in accordance with the screening detailed in paragraph 6.8 of these guidelines.
- 6.13.5 Members considering the installation of WS Tanks are obliged to follow the Association’s approval process set out herein, the cost of which will be for their account, namely:
- 6.13.5.1 Written application must be made to the Association;
- 6.13.5.2 The application must include a formal plan (“drawing”) of the WS Tank;
- 6.13.5.3 The application must include a site-plan of their own and of all surrounding dwellings (“proximity dwelling”), such site-plan intended to show the positioning of the WS Tank on the member’s property as well as positioning in relation to proximity dwellings;
- 6.13.5.4 The application must include a list of dimensions and specifications of the proposed WS Tank.

7. **PROHIBITED MATERIALS AND FINISHES**

- 7.1 No flat roofs are permitted, save for instances to join portions of the dwelling to each other, in which case these must be constructed of concrete and must have a non-reflective finish.



-
- 7.2 Pre-cast concrete or face brick walls.
- 7.3 Exposed concrete finishes to driveways and walk-ways.
- 7.4 Unpainted reflective steel sheeting, whether to roofs, gutters, down pipes or any other components of the external finishes.
- 7.5 Razor wire, security spikes or similar features.
- 7.6 Garage doors constructed from any material other than timber.
- 7.7 Insitu cast concrete panels with a brick or any other pattern imprinted into the surface thereof.
- 7.8 Wood panel picket fencing and/or screening. It is recorded that the management and regulation of the types of fencing and/or screening used by members on the Estate by the Association had not been clearly regulated prior to the acceptance of these RULES by the members. The result was that certain members now have varying fence/screening-types of varying materials installed on their properties that do not comply with the standards set by the Association as described in these RULES. As a result hereof, the following transition measures will apply to the affected members, namely:
- 7.8.1 Relevant fences/screens must be painted in shades of green or brown so as to blend with the surrounding landscape of the Estate;
- 7.8.2 Relevant fences/screens must be landscaped to be screened to the degree that the fences are not visible from the street or neighbouring properties;
- 7.8.3 Such landscaping to be installed so as to achieve the required screening within 6 (six) months from date of acceptance of these RULES;
- 7.8.4 When affected members decide to have the relevant fences/screens replaced, or should the Association decide that the applicable fences/screens require replacement as a result of disrepair, the replacement fences/screens must comply with the standards set by the Association as described elsewhere in these RULES, it being recorded that the cost hereof will be for the member's account.
- 7.9 Steel window and door frames.
- 7.10 In the event of a member wanting to utilise a finish not described in the RULES, approval of the ARC is required.

8. **SUBMISSION OF BUILDING PLANS**

- 8.1 Before plans, which are submitted for approval to the Association, will be scrutinized, the following must be paid to the Association, namely:
- 8.1.1 A plan scrutiny fee per submission, which amount will be recovered from the member via the member's levy account with the Association;
- 8.1.2 A plan approval fee, the amount of which is dependent on the regulations of the Local Authority, is payable per dwelling, but only if the local council requests payment of this particular amount.



-
- 8.1.3 The following plans are to be submitted for scrutiny/approval:
- 8.1.3.1 All plans required by the ARC of the Association and the Local Council; coloured in, according to Local Council regulations;
- 8.1.3.2 Plans so submitted must include the following drawings:
- 8.1.3.2.1 Floor plan;
- 8.1.3.2.2 Elevations;
- 8.1.3.2.3 Sections;
- 8.1.3.2.4 Roof pitches and gradients;
- 8.1.3.2.5 Site plan;
- 8.1.3.2.6 Landscaping plan;
- 8.1.3.2.7 Engineer's drawings as and where applicable;
- 8.1.3.2.8 Drawings depicting gradient management so as to comply with the RULES;
- 8.1.3.2.9 Drawings depicting storm water management.
- 8.1.3.3 One further set of the above plans which have been rendered so as to give an accurate indication of the materials to be used, and the colours thereof.
- 8.1.4 The set of rendered drawings will be retained by the Association for its records. A schedule of area is required indicating the areas of the site, ground floor and first floor, areas of covered patios are also required. Coverage is to be given on the drawings as a percentage of the site area.
- 8.1.5 The member is to sign each drawing submitted, stating that the Architectural Rules and Guidelines have been understood and complied with.
- 8.1.6 Both the architect and the engineer, duly registered, is to sign each drawing.
- 8.1.7 The following items must be clearly shown on the plans:
- 8.1.7.1 Area of dwelling including patios and outbuildings
- 8.1.7.2 Coverage (%)
- 8.1.7.3 FAR
- 8.1.7.4 Building lines, incorporating approvals for any relaxation; whether by the ARC and/or by the owner of neighbouring properties
- 8.1.7.5 Servitudes, if applicable
- 8.1.7.6 All external finishes including a colour specification
- 8.1.7.7 Elevations and sections
- 8.1.7.8 Building height restrictions
- 8.1.7.9 Drainage and storm water treatment, depicting the management thereof and how it will be concealed
- 8.1.7.10 Layout of driveway and other paved areas



9. **LANDSCAPING PLANS AND PROTOCOLS**

9.1 **Landscaping Plans**

9.1.1 Members are must provide the ARC with Landscaping Plans for new landscape installations, or should they wish to change existing landscape installations or wish to embark on complete landscape overhauls on their properties. Landscaping Plans is the vehicle utilised by the ARC to ensure that the landscaping objectives and measures of the Association are complied with - these objectives and measures can be found under paragraph 5.1 of the Community Participation Rules section of the RULES attached to the Memorandum of Incorporation of the Association

9.1.2 Landscaping Plans, which must be "TO SCALE" drawings, must meet the following requirements when submitted to the ARC for approval, namely:

9.1.2.1 The following information is required in a TITLE BLOCK to identify the Landscape Plan:

9.1.2.1.1 the name of the member;

9.1.2.1.2 the stand number of the member (referred to as the "Subject Property");

9.1.2.1.3 the estimated extent in square metres of the area that will be landscaped (referred to as the "Landscape Area" and the landscaping work embarked on referred to as the "Project");

9.1.2.1.4 the name and contact details of the landscape service provider, if applicable;

9.1.2.1.5 the signature of the member and the date on which the Landscape Plan was signed (this date referred to as the "Plan Date");

9.1.2.1.6 the signature of the member(s) owning directly adjacent neighbouring properties (referred to as the "Neighbouring Properties"), if the landscape that is undertaken has an impact on them;

9.1.2.1.7 provision for the ARC to indicate that the Landscape Plan has been approved – space for a signature and a date is required;

9.1.2.2 Two sets of Landscape Plans must be submitted – once approved, the ARC will retain one copy and return the other copy to the member.

9.1.2.3 The area to be landscaped is the primary indication/depiction required by the ARC on Landscaping Plans.

9.1.2.4 The Landscape Area includes the relevant area to be landscaped on the Subject Property as well as the areas, 2 metres wide to either side of the Neighbouring Properties, which must include the verges of the Subject Property and the Neighbouring Properties (the said properties collectively referred to as the "Affected Properties").

9.1.2.5 The boundaries of the Subject Property, including all servitudes and the positions of services (electrical, water, sewer, communication and storm water – as and where applicable).

9.1.2.6 The stand numbers of the Affected Properties.

9.1.2.7 The verge areas and position of the applicable street(s) of the Affected Properties, showing their relation to each other.

9.1.2.8 Existing buildings, swimming pools and/or structures found on the Affected Properties or the relevant portions thereof (utilised to establish their proximity to the new landscaping being undertaken and to judge the privacy the new landscaping offers).

9.1.2.9 **Existing landscape and hardscape of the Affected Properties:**

9.1.2.9.1 The exact position of trees and shrubs (in other words, all large plant species, irrespective of their size on the Plan Date);



- 9.1.2.9.2 The position of the ground covers, small plant species and lawns;
9.1.2.9.3 The exact position of Hardscaping (Hardscaping includes water features, paving, pots, planters, fencing, retaining structures, permanent garden furniture, stepping stones, gravelled areas, steps, and the like).
- 9.1.2.10 New landscape and hardscape of the Subject Property:
- 9.1.2.10.1 Clearly identify the trees and shrubs to be removed (in other words, all large plant species, irrespective of their size on the Plan Date), as well as any Hardscape;
9.1.2.10.2 The exact position of NEW trees and shrubs (in other words, all large plant species, irrespective of their size on the Plan Date);
9.1.2.10.3 The position of NEW ground covers, small plant species and lawns;
9.1.2.10.4 The exact position of NEW Hardscaping, together with the specification of the materials to be used.
- 9.1.2.11 Any changes to the landscape and hardscape of Neighbouring Properties (as and when applicable):
- 9.1.2.11.1 Clearly identify the trees and shrubs to be removed (in other words, all large plant species, irrespective of their size on the Plan Date), as well as any Hardscape;
9.1.2.11.2 The exact position of NEW trees and shrubs (in other words, all large plant species, irrespective of their size on the Plan Date);
9.1.2.11.3 The position of NEW ground covers, small plant species and lawns;
9.1.2.11.4 The exact position of NEW Hardscaping, together with the specification of the materials to be used.
- 9.1.2.12 Other Landscape Plan items:
- 9.1.2.12.1 Clearly identify all proposed platforms, berms and banks;
9.1.2.12.2 Clearly indicate Storm Water management controls;
9.1.2.12.3 If applicable, clearly indicate the placement of irrigation systems.
- 9.1.2.13 Landscaping Species to be planted on the Affected Properties
- 9.1.2.13.1 The Landscaping Plan must include a Planting Palette, such Planting Palette to only include plant species found in the Approved Plant List;
9.1.2.13.2 The Planting Palette comprises a legend, which is a collection of symbols and coloured-in areas together with a description for such symbols and coloured-in areas;
9.1.2.13.3 Symbols are utilised for trees and shrubs (in other words, all large plant species, irrespective of their size on the Plan Date), while coloured-in areas are utilised for ground covers, small plant species and lawns;
9.1.2.13.4 Symbols and coloured-in areas are accurately placed in the Landscape Area according to the PZE Landscape Protocols, which will ultimately become the design of the New Landscape Area.
- 9.1.2.14 A proposed Bill of Quantities must accompany the Landscaping Plan presented for approval to the ARC, which as a minimum must include the following information, namely:
- 9.1.2.14.1 The estimated extent in square metres of the Landscape Area;
9.1.2.14.2 The plant species to be used, depicting the following per specie:
- 9.1.2.14.2.1 The name of the plant specie
9.1.2.14.2.2 The bag size in litres of the plant specie



-
- 9.1.2.14.2.3 The number of each plant specie
 - 9.1.2.14.3 The ground cover plug species to be used, depicting the following per specie:
 - 9.1.2.14.3.1 The name of the ground cover plug specie
 - 9.1.2.14.3.2 The number of each ground cover plug specie
 - 9.1.2.14.4 The estimated extent in square metres of the lawned area;
 - 9.1.2.14.5 The estimated extent in square metres of the Hardscape area;
 - 9.1.2.14.6 The total amount of compost to be used for the project;
 - 9.1.2.14.7 The total amount of fertilizer to be used for the project;
 - 9.2 Landscaping Protocols
 - 9.2.1 The Association promotes biodiversity, not only on the individual stands within its boundaries, but on the Estate as a whole, and emphasises the importance of under-planting shrubs and trees with ground covers, smaller plants and lawns to curb erosion and to “green” the environment.
 - 9.2.2 To achieve the minimum biodiversity requirement of 65 plant species set in the Environmental Management Plan for PZE, a minimum of 40 plant species must be incorporated into all Landscaping Plans.
 - 9.2.3 Lawn area restrictions
 - 9.2.3.1 Verges: Lawns for the length of the stand – from a minimum of 500mm to a maximum of 1000mm wide;
 - 9.2.3.2 Stand boundaries between neighbours: no lawns closer than 2 metres from the boundary for the length of the boundary.
 - 9.2.4 Minimum planting densities (calculated in relation to the Landscape Area)
 - 9.2.4.1 Trees: 1 tree for every 20 m²;
 - 9.2.4.2 Shrubs: 1 shrub for every 5 m²;
 - 9.2.4.3 Ground cover plugs per m², dependant on slope:
 - 9.2.4.3.1 Flat to 10 degrees - 10 plants
 - 9.2.4.3.2 10 to 15 degrees - 12 plants
 - 9.2.4.3.3 16 to 20 degrees - 15 plants
 - 9.2.4.3.4 21 to 25 degrees - 20 plants
 - 9.2.4.3.5 More than 25 degrees - 25 plants
 - 9.2.4.4 Smaller plant species per m², dependant on bag size:
 - 9.2.4.4.1 1ℓ and 2ℓ bags: 8 plants per m²
 - 9.2.4.4.2 4ℓ bags: 5 plants per m²
 - 9.2.4.5 Minimum compost and fertilizer quantities
 - 9.2.4.5.1 10kg organic compost per m²
 - 9.2.4.5.2 100g synthetic or organic fertilizer per m²



9.3 Implementation and completion of the Project

- 9.3.1 The member may only commence with the Project once the ARC has approved the Landscape Plan.
- 9.3.2 The member is obliged to advise the ARC when the Project is complete at which stage the ARC will inspect the Landscape Area and sign off on the Project if the Project is satisfactorily completed in terms of this directive.
- 9.3.3 The ARC reserves the right to request a member to perform remedial action to any area of the Project found to be lacking or not in accordance with this directive.

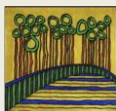

PORT ZIMBALI ESTATE HOME OWNERS' ASSOCIATION (NPC)

CONTRACTOR'S CODE OF CONDUCT

1. INTRODUCTION

- 1.1 Another of the main objectives of the Association is to ensure that all building, construction or installation activities on the Estate occurs with the least possible disruption to residents and that the building work, construction and/or installation conforms to the designs as approved by the Architectural Review Committee ("ARC") of the Association.
- 1.2 Members wanting to undertake building, construction or installations on the Estate are obliged to ensure that –
 - 1.2.1 they sign a copy of this Contractor's Code of Conduct ("CCC");
 - 1.2.2 the building contractors and/or any other contractors in their employ sign the CCC;
 - 1.2.3 they present the duly signed CCC together with the application for a Construction and/or Installation Clearance Certificate to the Association;
 - 1.2.4 they provide their building contractors and/or any other contractors in their employ with a copy of the Security Policy and Procedures of the Association; and
 - 1.2.5 they and their building contractors and/or any other contractors in their employ strictly adhere to the stipulations thereof.
- 1.3 The Association reserves the right to implement additional Conduct Rules on any site and/or to delete/amend/expand any of the conditions of the CCC at its sole discretion.

2. LEGAL STATUS

- 2.1 The by-laws of the Local Authority and the National Building Regulations relating to construction activities apply to the Estate. In the event of a conflict between the by-laws and these RULES, the stipulations of the RULES shall prevail.
- 2.2 The conditions governing building activity, which are set out in this CCC are RULES adopted by the members of the Association and are therefore binding on all members and their occupants and, through them, on their contractors and sub-contractors and other parties who are on the Estate at their invitation.
- 2.3 Members are obliged to ensure that their occupants, building contractors and sub-contractors and other visitors are aware of these conditions and comply strictly with them.



- 2.4 Members are therefore obliged to include this CCC in its entirety in any building contract concluded in respect of their property on the Estate (and to procure their inclusion in any sub-contract) and all such contracts must be submitted to the ARC for prior approval.
- 2.5 The Association has the right to suspend any building activity in contravention of any of the provisions of the CCC or the RULES and/or the right to fine a member and/or contractor, and the Association accepts no liability whatsoever for any loss sustained by a member as a result thereof.
- 2.6 The Association accepts no responsibility or liability for any injury, loss of life, damage or loss of materials or equipment during building operations.
- 2.7 Should a contractor breach or allow the breach of any provision of these rules by his employees, workers, a sub-contractor or its workers, the Association may itself rectify the breach as deemed necessary and claim any expense from the contractor and/or suspend building activity until such breach is remedied and in addition impose an appropriate fine. It may do so at any time and without notice and without recourse from the owner and/or contractor and/or sub-contractor.
- 2.8 The contractor and member undertake to comply with the provisions of the CCC, in addition to any further provisions, which may be promulgated by the Association from time to time in the form of a written notification and to ensure compliance by any sub-contractor employed by the contractor and by all employees and/or other workers.
- 2.9 Any contractor who fails to comply with these rules may be prohibited from entering the Estate and neither the member nor the contractor will have any claim of whatever nature against the Association as a result thereof.

3. **GENERAL CONDITIONS**

- 3.1 Contractor activity may only commence once the member is in possession of a Construction and/or Installation Clearance Certificate. The certificate must be in possession of the Contractor or the member at all times and must be presented upon request from either Estate Management, or a Security Officer, or a member of the Board of Directors, or the Managing Agent.
- 3.2 Construction and/or Installation Clearance Certificate
- 3.2.1 A member must apply to the Association for a Construction and/or Installation Clearance Certificate to be issued. The certificate will be issued by the Association once it is satisfied with the content of the application made. The application will consist of the following, namely:
- 3.2.1.1 A duly completed and signed Application for a Construction and/or Installation Clearance Certificate (copy of the prescribed form is attached to these RULES);
- 3.2.1.2 A copy of the approved plans as contemplated in paragraph 1.3.4 of the Architectural Rules and Guidelines;
- 3.2.1.3 A copy of the building contract entered into between the member and the contractor and sub-contractors;



- 3.2.1.4 A copy of the contractor's reigning "paid-up" BUILDER'S ALL RISK INSURANCE POLICY in which it must be evident that the Association and any other member of the Association is sufficiently covered against any claim they may make as a result of potential losses resulting from construction and installation activities to be undertaken;
- 3.2.1.5 A duly completed CCC, signed by both the member and the contractor;
- 3.2.1.6 Receipt of the relevant access application for access forms as prescribed in the Security Policy and Procedures for Longer-term contractors and their workers and employees;
- 3.2.1.7 Payment of the Security Deposit, if applicable. The RULES pertaining to a Security Deposit are as follows:
- 3.2.1.7.1 The member is responsible for the payment of the deposit amount;
- 3.2.1.7.2 The payment of the deposit amount is in the absolute discretion of the Board of Directors, but in any event, payable in either or both of the followings instances:
- 3.2.1.7.2.1 where the cost of the subject project is in excess of R40,000 (forty thousand Rand); and
- 3.2.1.7.2.2 where the member, in terms of these RULES, is obliged to present drawings and/or plans to the Architectural Review Committee of the Association for approval.
- 3.2.1.7.3 The Security Deposit amount is R6,000.00 (six thousand Rand);
- 3.2.1.7.4 The Security Deposit will be utilised to make good any damaged kerbing, roadways, pavements, manhole covers and any other infrastructure of the Association once construction activities commences and is caused by the contractor(s).
- 3.2.1.7.5 Taking the content of this paragraph 3.2.1.7 into account, any balance remaining will be refunded to the member subject to the following conditions:
- 3.2.1.7.5.1 request by the member for Estate Management to complete a site and Estate inspection, the content of which to be recorded on the relevant application form;
- 3.2.1.7.5.2 the aim of the site inspection is not to approve or ensure the quality of the work;
- 3.2.1.7.5.3 the aim of the site inspection is to ensure that –
- 3.2.1.7.5.3.1 the work performed and completed conforms to the plan submitted and approved;
- 3.2.1.7.5.3.2 the work is consistent with the Architectural Rules and Guidelines;
- 3.2.1.7.5.3.3 no damage was caused to any infrastructure of the Association, or in the event of damage having been caused, that such damage has been remedied to the satisfaction of Estate Management;
- 3.2.1.7.5.3.4 no damage was caused to the property of a neighbouring or any other member of the Association, or in the event of damage having been caused, that such damage has been remedied to the satisfaction of Estate Management;
- 3.2.1.7.5.3.5 the contractor has complied with all the provisions of the CCC;
- 3.2.1.7.5.4 that the completed site and Estate inspection is found satisfactory.
- 3.2.2 In the event of a member/contractor having to acquire a Construction and/or Installation Clearance Certificate, such member/contractor must make a monthly contribution to the security of the Estate for the duration such contractor will be present on the Estate to complete the relevant contract. The contribution is R1,000.00 per month or part thereof.
- 3.3 Contractor activity may only commence once the contractor(s) has arranged for access to the Estate for his staff/workers and vehicles as governed by the Security Policy and Procedures of the Association.



3.4 Accountability and Insurance

3.4.1 The Contractor will provide the Association with a copy of his "paid-up" reigning BUILDER'S ALL RISK INSURANCE POLICY and irrevocably undertakes to ensure that the policy remains "paid-up" for the duration of the contract period and/or the construction/installation is completed, whichever occurs last in time.

3.4.2 Contractors shall not store any material, or do or permit or allow to be done, any other dangerous act in or on the building site or on the common property that will or may increase the rate of the premium payable by the neighbours or the Association on any insurance policy.

3.5 Screening, signage and securing of building site

3.5.1 The contractor must screen the entire building site (should a vacant adjacent site be used for storage purposes as contemplated in these RULES, this vacant adjacent site will be regarded as part of the building site).

3.5.2 Screening must be erected out of green shade-netting with a minimum shade-factor of 75% (seventy five percent), which must be secured to wire strands that are attached to gum-poles. The installation must be of a sufficient quality so as to remain neat for the relevant construction period on the building site.

3.5.3 The building site must have access entrance gates, which must be locked when the building site is unattended.

3.5.4 No building activity shall commence on the designated building site unless a screened ablution facility, connected to the sewerage system, is erected, or an alternative facility approved by the Association is erected.

3.5.5 The contractor must erect relevant "indemnification" and "right of admission reserved" signage at the entrance to the site.

3.5.6 No advertising or sub-contractors boards will be permitted. Only the approved professional's information board will be permitted - the Association must approve the design of the board before it is erected on the site.

3.6 Heavy vehicles

3.6.1 Heavy vehicles, such as building material delivery vehicles, are allowed access onto the Estate subject to the following conditions:

3.6.1.1 The Gross Vehicle Mass ("GVM") displayed on the licence disc of the vehicle must not exceed 10 ton (10,000 kg);

3.6.1.2 The vehicle must not have a double differential;

3.6.1.3 The vehicle must not have a double axel;

3.6.1.4 The vehicle must not have a horse and trailer configuration;

3.6.1.5 The vehicle must not be an articulated vehicle;

3.6.1.6 The vehicle must preferably be able to park on the drive-way of the relevant property, but if this is not possible, the vehicle may park in the road as long as it doesn't cause an obstruction for passing traffic;

3.6.1.7 The height of the vehicle may not exceed 3,5 metres



- 3.6.2 Should heavy vehicles not meet the above conditions, a shuttle delivery service must be arranged with the Association.
- 3.6.3 In the event of a contractor requiring a relaxation of the access limitations RULE, application must be made to the Association on the prescribed form (Application for relaxation of the RULE for use of Heavy Vehicle), which is to be delivered to Estate Management and to be approved by the Association, prior to access being granted to such heavy vehicle for which application is made. Each access request will carry a mandatory ROAD FUND contribution, the amount of such contribution being in the discretion of the Association and such contribution being recovered against a member's levy account with the Association.
- 3.6.4 The contributions so made and received, are earmarked for the repair of any damage to the road surface, and does not, under any circumstance whatsoever, absolve any member or contractor from the responsibility of ensuring that damage is not caused to any infrastructure found on the Estate – including items such as the roads, road-surfaces, kerbing, landscaping, road signage, fire hydrants, electrical kiosks, water and sewer installations, etc. In the event of damage of any nature whatsoever being caused, the member will be held accountable for the expense that will need to be incurred to re-instate such damage infrastructure item to original state.
- 3.7 Street usage
- 3.7.1 Save where inconsistent with these rules, the National Road Traffic Act, No 93 of 1996, applies.
- 3.7.2 The speed limit in the Estate is 25 km per hour – all construction vehicles and vehicles in excess of 5 ton must adhere to a speed limit of 15 km per hour.
- 3.7.3 Where materials are off-loaded by a supplier on or partly encroaching onto the verge or roadway, the materials must be moved onto the site by the contractor on the same day. No material must be allowed to remain on the roadway or pavement and it is the responsibility of the contractor and owner to clear the roadway of all such materials the same day. The same applies to sand or rubble washed onto or landing on the road during building operations.
- 3.7.4 Littering and the collection of rubble in the streets and open spaces is prohibited.
- 3.7.5 No building materials may be off-loaded onto the road or the verges.
- 3.7.6 Contractors may not leave any obstruction on any part of the streets that will impede the free flow of pedestrian or vehicular traffic.
- 3.7.7 The Association will define delivery routes and delivery hours from time to time and all contractors are to obtain these restrictions from Estate Management.
- 3.7.8 Fines will be imposed by the Association on contractors and delivery vehicles that spill material en route, damage roadways and kerbing, stain road surfaces and that damage any other infrastructure of the Association and generally create a nuisance within the Estate.
- 3.8 Hours
- 3.8.1 Contractor activity is only permitted between the following hours, Mondays to Saturdays:

<u>Weekdays</u>	<u>Saturdays</u>
06:30 – 18:00	06:30 – 16:00



3.8.2 Delivery of supplies is only permitted between the following hours, Mondays to Saturdays:

<u>Weekdays</u>	<u>Saturdays</u>
07:30 – 17:30	07:30 – 16:00

3.8.3 No construction activity or delivery of supplies is to take place on Sundays and public holidays, as these days are viewed as private time for residents.

3.9 Refuse disposal

3.9.1 The by-laws of the Local Authority relating to refuse disposal applies to the Estate. In the event of a conflict between the by-laws and these RULES, the stipulations of the RULES shall prevail.

3.9.2 In respect of domestic refuse generated by the employees, staff and workers of the contractors, the contractors must –

3.9.2.1 ensure they are in possession of the prescribed refuse bin, failing which, acquire a prescribed refuse bin, for depositing domestic refuse;

3.9.2.2 maintain their refuse bins in a hygienic and dry condition and keep the refuse bin within the courtyard area of his private property;

3.9.2.3 only deposit domestic refuse contained in black plastic refuse bags in the refuse bins;

3.9.2.4 place all refuse that will cause their refuse bins to overflow in black refuse bags in the refuse bins in the refuse area adjacent to the gate-house at the entrance of the Estate - under no circumstances may such refuse be placed on any other part of the common property or a neighbour's property, whether vacant or not;

3.9.2.5 place the refuse bin outside the building site before 08:00 on collection days and return it to the building site as soon as possible after the refuse has been collected, in any event by no later than 16:00 on the relevant collection day.

3.9.3 Contractors may not dispose of any waste, item, article or substance in either their own refuse bins or the refuse bins in the refuse area that is either poisonous, a health hazard or detrimental to the safety of the owners or occupants of the Estate. Such waste, items, articles or substances must be disposed of as prescribed by the by-laws and regulations of the Local Council relevant to such waste, items, articles or substances.

3.9.4 All building rubble shall be removed by the contractors at their own cost.

3.9.5 The burning of rubble of whatever nature within the Estate is forbidden.

3.10 Eradication of pests

3.10.1 The by-laws of the Local Authority relating to pests apply to the Estate. In the event of a conflict between the by-laws and these RULES, the stipulations of the RULES shall prevail.

3.10.2 A contractor shall keep his building site free of white ants, borer and other wood destroying insects, all other insect infestation types (such as fleas, cockroaches, fish moths, etc.) and rodents (such as rats, mice, etc.) and to this end shall permit the Association, the managing agent, and their duly authorised agents or employees, to enter the building site from time to time for the purpose of inspecting the building site and taking such action as may be reasonably necessary to eradicate any such pests.



- 3.10.3 The costs of the inspection, eradicating any such pests as may be found within the building site, replacement of any infrastructure belonging to the Association that may be damaged by any such pests shall be borne by the contractor.
- 3.11 Miscellaneous security RULES
 - 3.11.1 All the contractor’s workers and/or his sub-contractor’s workers must enter and exit the Estate on foot through the dedicated security electronic turnstile mechanism/system. To gain access to the Estate, such workers must be registered for access to the Estate. No contractor’s workers will be allowed to enter and exit the Estate on or inside any vehicle other than the driver of such vehicle.
 - 3.11.2 The contractor’s workers and/or his sub-contractors and the sub-contractor’s workers are granted access to the Estate, but to a specific site in terms of the approval given by the Association via the relevant Construction and/or Installation Clearance Certificate. None of these sub-contractors and workers have access to any other part of the Estate or may not roam on any common property of the Estate and in doing so will be in breach of the RULES and will be liable for a fine or may be denied access to the Estate in the sole discretion of the Board of Directors.
 - 3.11.3 The Association will require payment by any contractor and/or sub-contractor for each access registration registered.
 - 3.11.4 With regard to materials and tools, contractors are advised that materials and tools will be permitted to enter the Estate via vehicle or other means, but the removal of such materials and tools from the Estate must be accompanied by a removal permit describing such materials and tools. A removal permit will be issued by the main contractor’s site Manager.
 - 3.11.5 Under no circumstances may a contractor employ employees who are not in possession of a legitimate South African Identity Document.
 - 3.11.6 Contractors and/or employees who are not in possession of the aforementioned document will not be allowed access into the Estate.

We, the member and the Contractor, by virtue of our signature hereto, acknowledge, accept and agree to be bound by the content of this CCC and the RULES of the Association.

NAME (Print)

MEMBER

UNIT NO

DATE

NAME (Print)

CONTRACTOR

DATE



PORT ZIMBALI ESTATE HOME OWNERS' ASSOCIATION (NPC)

SECURITY POLICY AND PROCEDURES

1. INTRODUCTION

- 1.1 The high standard of the security in and on the **Estate**, but more importantly the objective of not only continually sustaining the high standard of the security enjoyed, but also striving to enhance and improve on this standard, is one of the primary reasons why **Members** and/or their **Tenants** have chosen to reside on the **Estate** and/or have chosen to invest in the **Estate**. The **Security Service Provider** shares in the responsibility with the **Association** and its **Members** to achieve this objective.
- 1.2 Having computerised and automated access and exit control equipment at the entrance gate to the **Estate**, operational measures and procedures are required to achieve uncompromising, but acceptable streamlined operations for entering the **Estate**.
- 1.3 To achieve the latter, it is of utmost importance for everyone concerned to not only adhere to and abide by these measures and procedures, but also to assist the **Association** and the **Security Officers** with the continued application and maintenance thereof.
- 1.4 **Positive Identification** is a non-negotiable requirement for any individual that requires access to the **Estate**.
- 1.5 The right to access the **Estate** is in the discretion of the **Association** and as such the **Association** holds the right to refuse access to any party that does not meet the conditions/requirements contained in this Security Policy and Procedures document or that is in breach of any stipulation/condition contained in the **MOI** or **RULES** of the **Association**.
- 1.6 Should the **Association** elect to fine an individual present on the **Estate** for a transgression of the **RULES**, including this **Security Policy**, such fine will be recovered from the relevant **Authorised Access Arranger** (should the particular individual be a **Tenant**, the fine will be recovered from the **Owner**, who must recover the amount from the **Tenant**), as the case might be. The **ACCS** provides for the "suspension" of an individual's registration as entrant – the **Association** will, in its sole discretion, apply the "suspension" feature to an individual, such application of the "suspension" feature being dependent on the number and nature of transgressions of the **RULES** contained in the **MOI** of the **Association** by the relevant individual.



2. **SECURITY POLICY AND PROCEDURES**

*Note: A "word" or "series of words" appearing in **BOLD** text implies that a definition, that will provide clarity, is available in the Security Policy and Procedures (paragraph 3) for such "word" or "series of words".*

2.1 **Member**

2.1.1 **Members**, by virtue of their ownership of a **Unit** in the **Estate** are entitled to access the **Estate**, whether resident on the **Estate** or not.

2.1.2 Access to the **Estate** is arranged by following the **Take-on Process**, where after, once successful, the **Member** will be registered on the **ACCS** as a **Regular Entrant**.

2.1.3 Should the finger print of a **Member** fail to register on the **ACCS**, the relevant individual will be issued with a **Registered Access Card**.

2.1.4 The cost of registration can be found in the list of "Levies, Fees, Charges and Recoveries" as published on the **Website** by the Board of Directors of the **Association** from time to time, which costs will be for the **Owner's** Account.

2.1.5 Access restrictions, if any, apply according to the **Access Parameters**.

2.1.6 **Members**, validly registered, enter or exit the **Estate** by scanning their finger print or **Registered Access Card**, as the case might be, on a **Gateway Device Reader** which will cause the relevant **Gateway Device** to open.

2.1.7 **Members** may appoint **Domestics**, which implies access to the **Estate** for such **Domestics**, and they must do so by following the **Take-on Process** relevant to **Domestics**, where after, if successful, the **Domestics** will be registered on the **ACCS** as **Regular Entrants**.

2.1.8 **Members** may appoint a contractor to do maintenance/alterations/additions at their **Property**. **Members** are obliged to meet the obligations placed on them in terms of paragraph 15.3 of the Community Participation Rules section of the **RULES**, styled "Construction and/or Installation Clearance Certificate", before appointing such contractor. Should the period required to complete the maintenance/alterations/additions be less than 5 days, for purposes of access to the **Estate** such contractor is regarded as an **Irregular Entrant**. Should the period be 5 days or more, for purposes of access to the **Estate** the **Member** is regarded as a **Main Contractor** and such contractor is regarded as a **Subcontractor**.

2.1.9 **Members** may arrange access for **Irregular Entrants** and do so by making use of **GateBook**.

2.1.10 A **Member** may gain access on foot to the **Estate** by following the process for **Pedestrians**.

2.2 **Tenant**

2.2.1 **Tenants**, by virtue of them entering into a legally binding lease agreement with an **Owner**, and the **Owner** successfully applying for a Tenant Clearance Certificate from the **Association** as provided for in paragraph 12.2 of the Community Participation Rules section of the **RULES** of the **Association**, are entitled to access the **Estate**.



-
- 2.2.2 Access to the **Estate** is arranged by following the **Take-on Process**, where after, once successful, the **Tenant** will be registered on the **ACCS** as a **Regular Entrant**.
- 2.2.3 Should the finger print of a **Tenant** fail to register on the **ACCS**, the relevant individual will be issued with a **Registered Access Card**.
- 2.2.4 The cost of registration can be found in the list of "Levies, Fees, Charges and Recoveries" as published on the **Website** by the Board of Directors of the **Association** from time to time, which costs will be for the **Owner's** Account. The **Owner** must recover the cost from the **Tenant**.
- 2.2.5 Access restrictions apply according to the **Access Parameters**.
- 2.2.6 **Tenants**, validly registered, enter or exit the **Estate** by scanning their finger print or **Registered Access Card**, as the case might be, on a **Gateway Device Reader** which will cause the relevant **Gateway Device** to open.
- 2.2.7 **Tenants** may appoint **Domestics**, which implies access to the **Estate** for such **Domestics**, and they must do so by following the **Take-on Process** relevant to **Domestics**, where after, if successful, the **Domestics** will be registered on the **ACCS** as **Regular Entrants**.
- 2.2.8 **Tenants** may arrange access for **Irregular Entrants** and do so by making use of **GateBook**.
- 2.2.9 **Tenants** MAY NOT appoint **Temporary Contractors** when the aim of such appointment is to modify or alter the exterior appearance of the improvements or the landscape on the **Property**. A **Member** must make these arrangements with the **Association**.
- 2.2.10 A **Tenant** may gain access on foot to the **Estate** by following the process for **Pedestrians**.
- 2.3 **Visitors**
- 2.3.1 If in possession of a **Preauthorisation Code**, a **Visitor** will be allowed access to the **Estate**.
- 2.3.2 Access to the **Estate** is arranged by an **Access Arranger** by following the **Access Authorisation Process**.
- 2.3.3 The **Visitor** will be provided with a **Temporary Access Card** on entry. The **Temporary Access Card** must be returned to the **Security Officer** when exiting, failing which, the cost of replacing the **Temporary Access Card** will be for the **Access Arranger's** account. In instances where a **Tenant** is an **Access Arranger**, the cost will be recovered from the **Owner**. The **Owner** must recover the cost from the **Tenant**.
- 2.3.4 A **Visitor**, if in possession of a valid **Temporary Access Card**, may wander on the communal areas of the **Estate**. However, should a **Visitor** have gained access onto the **Estate** in a manner in which a **Temporary Access Card** WAS NOT issued upon entry, such **Visitor** MAY NOT wander on the communal areas of the **Estate**, unless accompanied by the **Resident** whom the **Visitor** is visiting.
- 2.3.5 Access restrictions apply according to the **Access Parameters**. Note that **Access Parameters** for **Extended Stay Visitors**, **Visitors** (daily) and **Visitors** arranged by **Estate Agents** differ from each other.



- 2.3.6 **Visitors** may not gain access to the **Estate** as **Pedestrians**. Should a **Visitor** arrive on foot at the **Gatehouse** seeking access to the **Estate**, such **Visitor** must be fetched by the **Resident** personally in the relevant **Resident's** vehicle. Such **Visitor** is therefore not allowed to enter the **Estate** as a **Pedestrian**.
- 2.4 **Domestics**
- 2.4.1 **Members** or **Tenants** may appoint a daily **Domestic** or **Live-in Domestic**.
- 2.4.2 Only one female **Domestic** and one male **Domestic** is allowed per household.
- 2.4.3 In the instance of a **Live-in Domestic**, suitable accommodation must be utilised and not areas on the **Property** not designated for human accommodation.
- 2.4.4 Access to the **Estate** is arranged by following the **Take-on Process**, where after, once successful, the **Domestic** will be registered on the **ACCS** as a **Regular Entrant**.
- 2.4.5 Should the finger print of a **Domestic** fail to register on the **ACCS**, the relevant individual will be issued with a registered **Permanent Access Card**.
- 2.4.6 The cost of registration can be found in the list of "Levies, Fees, Charges and Recoveries" as published on the **Website** by the Board of Directors of the **Association** from time to time, which costs will be for the **Owner's** account. Should the **Domestic** be employed by a **Tenant**, the **Owner** must recover the cost from the **Tenant**.
- 2.4.7 Access restrictions apply according to the **Access Parameters**.
- 2.4.8 **Domestics**, validly registered, enter or exit the **Estate** by scanning their finger print or **Permanent Access Card**, as the case might be, on a **Gateway Device Reader** which will cause the relevant **Gateway Device** to open.
- 2.4.9 **Domestics** may not arrange access for **Irregular Entrants** onto the **Estate**.
- 2.4.10 **Domestics** may gain access to the **Estate** as **Pedestrians**, but they aren't allowed to enter **Properties** other than the **Property** to which they are appointed.
- 2.5 **Main Contractor**
- 2.5.1 **Main Contractors** are entitled to access the **Estate**.
- 2.5.2 Should an **Owner** wish to appoint a contractor to do alterations or additions to the **Owner's Property**, for purposes of this **Security Policy**, the **Association** regards the **Owner** as a **Main Contractor**.
- 2.5.3 Access to the **Estate** is arranged by following the **Take-on Process**, where after, once successful, the management officials and staff of the **Main Contractor** will be registered on the **ACCS** as **Regular Entrants**.
- 2.5.4 Should the finger print of any management official and/or staff member of the **Main Contractor** fail to register on the **ACCS**, the relevant individual will be issued with a registered **Permanent Access Card**.



- 2.5.5 The cost of registration can be found in the list of “Levies, Fees, Charges and Recoveries” as published on the **Website** by the Board of Directors of the **Association** from time to time, which costs will be for the **Main Contractor’s** account.
- 2.5.6 Access restrictions apply according to the **Access Parameters**. Note that **Access Parameters** for management officials differs from **Access Parameters** for staff members.
- 2.5.7 Taking **Access Parameters** into account, **Main Contractors**, validly registered, enter or exit the **Estate** by scanning their finger print or **Permanent Access Card**, as the case might be, on a relevant **Gateway Device Reader** which will cause the relevant **Gateway Device** to open.
- 2.5.8 **Main Contractors** may appoint **Subcontractors**, which implies access to the **Estate** for such **Subcontractors**, and they must do so by following the **Take-on Process** relevant to **Subcontractors**, where after, if successful, the **Subcontractors** will be registered on the **ACCS** as **Regular Entrants**.
- 2.5.9 **Main Contractors** may arrange access for **Irregular Entrants** and do so by making use of **GateBook**.
- 2.5.10 **Main Contractors** may not gain access to the **Estate** as **Pedestrians**.
- 2.5.11 The staff of a **Main Contractor** may only be present on the **Property(s)** at which they are working – in the event that they need to move from one site to another it must either be in a vehicle or they must wear clothing that identifies the **Main Contractor** by whom they are employed.
- 2.6 **Subcontractor**
- 2.6.1 **Subcontractors** are entitled to access to the **Estate** if formally appointed by a **Main Contractor**.
- 2.6.2 Access to the **Estate** is arranged by following the **Take-on Process**, where after, once successful, the management officials and staff of the **Subcontractor** will be registered on the **ACCS** as **Regular Entrants**.
- 2.6.3 Should the finger print of any management official and/or staff member of the **Subcontractor** fail to register on the **ACCS**, the relevant individual will be issued with a registered **Permanent Access Card**.
- 2.6.4 The cost of registration can be found in the list of “Levies, Fees, Charges and Recoveries” as published on the **Website** by the Board of Directors of the **Association** from time to time, which costs will be for the **Subcontractor’s** account. Note that should the Association fail to recover the costs from the **Subcontractor**, it has the right to recover the cost from the **Main Contractor**.
- 2.6.5 Access restrictions apply according to the **Access Parameters**. Note that **Access Parameters** for management officials differs from **Access Parameters** for staff members.
- 2.6.6 Taking **Access Parameters** into account, **Subcontractors**, validly registered, enter or exit the **Estate** by scanning their finger print or **Permanent Access Card** on a relevant **Gateway Device Reader** which will cause the relevant **Gateway Device** to open.
- 2.6.7 **Subcontractors** may not arrange access for **Irregular Entrants** onto the **Estate**.



- 2.6.8 **Subcontractors** may not gain access to the **Estate** as **Pedestrians**.
- 2.6.9 The staff of a **Subcontractor** may only be present on the **Property** at which they are working – in the event that they need to move from the **Property** at which they are working it must be in a vehicle.
- 2.7 **Recurring Contractor**
- 2.7.1 A **Recurring Contractor** provides a weekly or monthly service and is not found on a full-time basis on the **Estate**; such **Recurring Contractor** typically being a swimming pool maintenance service provider or a window cleaning service provider.
- 2.7.2 **Authorised Residents** are entitled to appoint a **Recurring Contractor** and do so by completing, signing and providing the relevant **Access Application Form**, together with the necessary supporting documentation to the **Estate Management**.
- 2.7.3 A **Recurring Contractor** normally provides its service at a number of **Properties** on the **Estate**.
- 2.7.4 Access to the **Estate** is arranged by following the **Take-on Process**, where after, once successful, the staff of the **Recurring Contractor** will be registered on the **ACCS** as **Regular Entrants**.
- 2.7.5 Should the finger print of the staff of the **Recurring Contractor** fail to register on the **ACCS**, the relevant individual will be issued with a registered **Permanent Access Card**.
- 2.7.6 Access restrictions apply according to the **Access Parameters**.
- 2.7.7 Taking **Access Parameters** into account, **Recurring Contractors**, validly registered, enter or exit the **Estate** by scanning their finger print or **Permanent Access Card** on a relevant **Gateway Device Reader** which will cause the relevant **Gateway Device** to open.
- 2.7.8 **Recurring Contractors** may not arrange access for **Irregular Entrants** onto the **Estate**.
- 2.7.9 **Recurring Contractors** may not gain access to the **Estate** as **Pedestrians**.
- 2.7.10 **Recurring Contractors** may only be present on the **Property(s)** for which they are appointed – in the event that they need to move from one Property to another it must be in a vehicle.
- 2.8 **Estate Agents**
- 2.8.1 An **Estate Agent** in possession of a valid Accreditation Certificate is entitled to access to the **Estate**.
- 2.8.2 Access to the **Estate** is arranged by following the **Take-on Process**, where after, once successful, the **Estate Agent** will be registered on the **ACCS** as a **Regular Entrant**.
- 2.8.3 Should the finger print of the **Estate Agent** fail to register on the **ACCS**, the **Estate Agent** will be issued with a registered **Permanent Access Card**.



- 2.8.4 The cost of registration can be found in the list of “Levies, Fees, Charges and Recoveries” as published on the **Website** by the Board of Directors of the **Association** from time to time, which costs will be for the estate agency that employs the **Estate Agent’s** account.
- 2.8.5 Access restrictions apply according to the **Access Parameters**.
- 2.8.6 Taking **Access Parameters** into account, **Estate Agents**, validly registered, enter or exit the **Estate** by scanning their finger print or **Permanent Access Card** on a relevant **Gateway Device Reader** which will cause the relevant **Gateway Device** to open.
- 2.8.7 **Estate Agents** may arrange access for **Visitors** onto the **Estate**. Note that such **Visitor** must at all times be accompanied by the **Estate Agent** when on the **Estate**.
- 2.8.8 **Estate Agents** and/or their **Visitors** may not gain access to the **Estate** as **Pedestrians**.
- 2.9 **Delivery Contractors**
- 2.9.1 If in possession of a **Preauthorisation Code**, a **Delivery Contractor** will be allowed access to the **Estate**.
- 2.9.2 Access to the **Estate** is arranged by an **Access Arranger** by following the **Access Authorisation Process**. A **Temporary Access Card** will be provided to the driver of the **Delivery Contractor’s** vehicle on entry.
- 2.9.3 Should passengers be present in the **Delivery Contractor’s** vehicle and if such passengers are required to effect the delivery to the relevant **Property** for which access was arranged, the passengers will gain access by following the **Temporary Registration Process**.
- 2.9.4 Access restrictions apply according to the **Access Parameters**.
- 2.9.5 **Delivery Contractors** may not gain access to the **Estate** as **Pedestrians**.
- 2.9.6 **Delivery Contractors** may only be present on the **Property** at which they are making a delivery – any movement on the **Estate** must be in a vehicle and accompanied by a **Security Officer** or the **Access Arranger**.
- 2.10 **Temporary Contractors**
- 2.10.1 If in possession of a **Preauthorisation Code**, a **Temporary Contractor** will be allowed access to the **Estate**.
- 2.10.2 Access to the **Estate** is arranged by an **Access Arranger** by following the **Access Authorisation Process**. A **Temporary Access Card** will be provided to the driver of the **Temporary Contractor’s** vehicle on entry.
- 2.10.3 Should passengers be present in the **Temporary Contractor’s** vehicle and if such passengers are required to effect the work required at the relevant **Property** for which access was arranged, the passengers will gain access by following the **Temporary Registration Process**.
- 2.10.4 Access restrictions apply according to the **Access Parameters**.
- 2.10.5 **Temporary Contractors** may not gain access to the **Estate** as **Pedestrians**.



- 2.10.6 **Temporary Contractors** may only be present on the **Property** at which they are working – any movement on the **Estate** must be in a vehicle and accompanied by a **Security Officer** or the **Access Arranger**.
- 2.11 **Casuals**
- 2.11.1 Individuals arriving on foot at the **Gatehouse** seeking to gain access to the **Estate** as a result of an **Access Arranger** entering into a temporary working arrangement with such individual is regarded as a **Casual**.
- 2.11.2 Access can only be arranged for a **Casual** on receipt of a personal request from an **Access Arranger**, the nature of such personal request to be the physical presence of the **Access Arranger** at the **Gatehouse** arranging such access with the **Security Officers**.
- 2.11.3 When the above arrangements are completed satisfactorily, access to the **Estate** is arranged by scanning the **Casual's** personal information directly into the **GateBook Device**. A **Temporary Access Card** will be provided to the **Casual** on entry.
- 2.11.4 The **Temporary Access Card** provided to the **Casual** must be returned to the **Security Officer** when exiting, failing which, the cost of replacing the **Temporary Access Cards** will be for the **Access Arranger's** account. In instances where a **Tenant** is an **Access Arranger**, the cost will be recovered from the **Owner**. The **Owner** must recover the cost from the **Tenant**.
- 2.11.5 Access restrictions apply according to the **Access Parameters**.
- 2.11.6 Should the said temporary working arrangement evolve into a more permanent arrangement, such more permanent arrangement evidenced by 5 days worked, the **Access Arranger** as **Resident** must make arrangements for the **Casual** to be registered as a **Domestic**, or the **Access Arranger** as **Main Contractor** must make arrangements for the **Casual** to be registered as a staff member.
- 2.11.7 A **Casual** may only be present on the **Property** in question.
- 2.11.8 **Casuals** may not gain access to the **Estate** as **Pedestrians**.
- 2.12 **Hawkers**
- 2.12.1 **Hawkers** are not allowed onto the Estate.
- 2.13 **Special arranged entries**
- 2.13.1 **Estate Management**, as **Access Arranger**, is responsible to make special arrangements for access onto the **Estate** for the following individuals (these individuals must gain access onto the **Estate** in a vehicle) who are regarded as **Irregular Entrants**:
- 2.13.1.1 Refuse removal vehicles and staff of the Local Authority.
- 2.13.1.2 Electricity meter reader staff of the Local Authority.
- 2.13.1.3 Water meter reader staff of the Water Provision Authority.
- 2.13.1.4 Representatives of the Sheriff.
- 2.13.2 **Estate Management** follows the **Access Authorisation Process**, when arranging access onto the Estate.

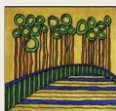

2.14 **Food Deliverers**

- 2.14.1 If in possession of a **Preauthorisation Code**, a **Food Deliverer** will be allowed access to the **Estate**.
- 2.14.2 Access to the **Estate** is arranged by an **Access Arranger** by following the **Access Authorisation Process**. A **Temporary Access Card** will be provided to the driver of the **Food Deliverer's** vehicle on entry.
- 2.14.3 Should passengers be present in the **Food Deliverer's** vehicle, such passengers must exit said vehicle before the **Food Deliverer's** vehicle may gain access to the **Estate**. These passengers may wait outside the gate for the **Food Deliverer** to return to the gate to exit the **Estate**.
- 2.14.4 A **Food Deliverer's** vehicle may be a motorcycle.
- 2.14.5 Access restrictions apply according to the **Access Parameters**.
- 2.14.6 **Food Deliverers** may not gain access to the **Estate** as **Pedestrians**.
- 2.14.7 **Food Deliverers** may only be present on the **Property** at which they are making a food delivery – any movement on the **Estate** by a **Food Deliverer** must be in a vehicle.

3. **DEFINITIONS**

*Note: **Definitions** found in this paragraph 3 only apply to the Security Policy and Procedures section of the RULES. The **Definitions** go beyond the purpose of defining the items listed. The **Definitions** also aim to provide RULES as and where the context applies.*

- 3.1 "**Access Application Forms**" means the **Access Application Forms** that can be found on the **Website** of the **Association**, which are to be viewed as part of the **Security Policy**, that must be completed, signed and provided to **Estate Management** together with the required supporting documentation, as the case might be, enabling **Estate Management** to register a **Regular Entrant** on the **ACCS** of the **Association**. The following **Access Application Forms** are available:
- | | | | |
|-------|---|---|------------|
| 3.1.1 | Access Application – Member | - | Annexure A |
| 3.1.2 | Access Application – Tenant | - | Annexure B |
| 3.1.3 | Access Application – Domestic | - | Annexure C |
| 3.1.4 | Access Application – Main Contractor Management | - | Annexure D |
| 3.1.5 | Access Application – Main Contractor Staff | - | Annexure E |
| 3.1.6 | Access Application – Subcontractor Management | - | Annexure F |
| 3.1.7 | Access Application – Subcontractor Staff | - | Annexure G |
| 3.1.8 | Access Application – Recurring Contractor | - | Annexure H |



- 3.2 "Access Arranger" means an **Authorised Resident**, the **Developer**, a **Main Contractor** management official, an **Estate Agent**, the **Managing Agent** and **Estate Management**.
- 3.3 "Access Authorisation" means that access to the **Estate** is authorised, subject to the **Access Parameters**, for an **Irregular Entrant**, which authorisation was attained by following the **Access Authorisation Process**. Proof of **Access Authorisation** is established once a valid **Preauthorisation Code** can be presented.
- 3.4 "Access Authorisation Process" means the process followed by an **Access Arranger** for an **Irregular Entrant** to be granted access onto the **Estate**, which entails the following:
- 3.4.1 The **Access Arranger** requests a **Preauthorisation Code** via the **GateBook App**.
- 3.4.2 After submitting a request for a **Preauthorisation Code**, the **GateBook App** returns a **Preauthorisation Code** to the **Access Arranger**, which the **Access Arranger** must provide to the **Irregular Entrant** in question – this can take place by "forwarding" the **Preauthorisation Code** to the **Irregular Entrant** from the **GateBook App** via SMS, WhatsApp, E-mail or phone call.
- 3.4.3 The **Preauthorisation Code** will be available on the **GateBook Device** for use by the **Security Officers** at the **Gatehouse** when the **Irregular Entrant** arrives and requests entry onto the **Estate**.
- 3.4.4 An **Irregular Entrant** will only be allowed access to the **Estate** if they are in possession of a valid **Preauthorisation Code** that is generated by **GateBook** when they arrive at the **Gatehouse**.
- 3.4.5 Only **Access Arrangers** can submit a request to **GateBook** for a **Preauthorisation Code** to be generated for use by an **Irregular Entrant**.
- 3.4.6 Notwithstanding an **Irregular Entrant** being in possession of a valid **Preauthorisation Code**, the **Irregular Entrant** must always present a valid driver's licence to the **Security Officer** to gain entry when arriving in a vehicle. Expired driver's licences are acceptable, but photocopies of driver's licences or obvious forgeries thereof are not acceptable.
- 3.4.7 In the event of such **Irregular Entrant** being a passenger on a vehicle of a **Temporary Contractor** or a **Delivery Contractor**, such **Irregular Entrant** must follow the **Temporary Registration Process**, which requires the **Irregular Entrant** to provide **Positive Identification** to the **Security Officer**.
- 3.4.8 The **Temporary Registration Process** does not apply to **Visitors** as the **Access Authorisation Process** sufficiently manages the registration of **Visitor** information.
- 3.4.9 The **Temporary Registration Process** is applied in the case of **Casuals**.
- 3.5 "Access Card" means a **Permanent Access Card** handed to a **Regular Entrant**, a **Registered Access Card** handed to a **Resident** or a **Temporary Access Card** handed to an **Irregular Entrant**.
- 3.6 "Access Event" means every instance that an **Access Card** or a fingerprint is scanned on a **Gateway Device Reader** at the **Gatehouse** to gain access to, or to exit the **Estate**.



- 3.7 “**Access Event Transaction**” means the information recorded on the **ACCS** for every **Access Event**, which includes the following:
- 3.7.1 Details of the individual triggering the event.
- 3.7.2 Date and time of event.
- 3.7.3 **Gateway Device** used for the event.
- 3.7.4 Whether the event is an entry to the **Estate** or whether it is for exiting from the **Estate**.
- 3.8 “**Access Parameters**” means day restrictions, hour restrictions and the period for which **Access Authorisation** will be valid, set on the **ACCS** for control purposes that **Regular Entrants** and **Irregular Entrants** are allowed to be present on the **Estate**. **Access Parameters** also includes the period of non-use of a **Gateway Device Reader** (where after **Access Authorisation** will once again be required), the **Gateway Device** that may be used, whether the Entrant must be escorted to his destination on the **Estate** and any single entry/single exit **Access Event** restriction. The following are the **Access Parameters** set for the various entrant types:
- 3.8.1 **Members**
- | | | |
|---------|--------------------------------------|-----------|
| 3.8.1.1 | Day restrictions | None |
| 3.8.1.2 | Hour restrictions | None |
| 3.8.1.3 | Validity period of authorisation | 24 Months |
| 3.8.1.4 | Non-use period | 12 Months |
| 3.8.1.5 | Gateway Device restriction | None |
| 3.8.1.6 | Escort or vehicle access restriction | None |
| 3.8.1.7 | Single entry/exit restriction | None |
- 3.8.2 **Tenants**
- | | | |
|---------|--------------------------------------|--|
| 3.8.2.1 | Day restrictions | None |
| 3.8.2.2 | Hour restrictions | None |
| 3.8.2.3 | Validity period of authorisation | 12 Months or date of expiry of lease, whichever occurs earlier in time |
| 3.8.2.4 | Non-use period | 3 Months |
| 3.8.2.5 | Gateway Device restriction | None |
| 3.8.2.6 | Escort or vehicle access restriction | None |
| 3.8.2.7 | Single entry/exit restriction | None |
- 3.8.3 **Domestics (daily)**
- | | | |
|---------|--------------------------------------|-----------------------------|
| 3.8.3.1 | Day restrictions | None |
| 3.8.3.2 | Hour restrictions | Allowed from 06:00 to 18:00 |
| 3.8.3.3 | Validity period of authorisation | 6 Months |
| 3.8.3.4 | Non-use period | 1 Month |
| 3.8.3.5 | Gateway Device restriction | Turnstile only |
| 3.8.3.6 | Escort or vehicle access restriction | None |
| 3.8.3.7 | Single entry/exit restriction | None |



3.8.4	Live-in Domestics	
3.8.4.1	Day restrictions	None
3.8.4.2	Hour restrictions	None
3.8.4.3	Validity period of authorisation	6 Months
3.8.4.4	Non-use period	1 Month
3.8.4.5	Gateway Device restriction	Turnstile only
3.8.4.6	Escort or vehicle access restriction	None
3.8.4.7	Single entry/exit restriction	None
3.8.5	Main Contractor Management	
3.8.5.1	Day restrictions	None
3.8.5.2	Hour restrictions	None
3.8.5.3	Validity period of authorisation	12 Months
3.8.5.4	Non-use period	3 Month
3.8.5.5	Gateway Device restriction	None
3.8.5.6	Escort or vehicle access restriction	None
3.8.5.7	Single entry/exit restriction	None
3.8.6	Subcontractor Management	
3.8.6.1	Day restrictions	Sundays and Public Holidays
3.8.6.2	Hour restrictions	
3.8.6.2.1	Work Day	06:30 to 18:00
3.8.6.2.2	Saturday	06:30 to 16:00
3.8.6.3	Validity period of authorisation	3 Months
3.8.6.4	Non-use period	3 Months
3.8.6.5	Gateway Device restriction	None
3.8.6.6	Escort or vehicle access restriction	Vehicular access on Estate only
3.8.6.7	Single entry/exit restriction	None
3.8.7	Main Contractor Staff	
3.8.7.1	Day restrictions	Sundays and Public Holidays
3.8.7.2	Hour restrictions	
3.8.7.2.1	Work Day	06:30 to 18:00
3.8.7.2.2	Saturday	06:30 to 16:00
3.8.7.3	Validity period of authorisation	6 Months
3.8.7.4	Non-use period	1 Months
3.8.7.5	Gateway Device restriction	Turnstile only, unless driver, then Gate
3.8.7.6	Escort or vehicle access restriction	Vehicular access on Estate only
3.8.7.7	Single entry/exit restriction	None
3.8.8	Subcontractor Staff	
3.8.8.1	Day restrictions	Sundays and Public Holidays
3.8.8.2	Hour restrictions	
3.8.8.2.1	Work Day	06:30 to 18:00
3.8.8.2.2	Saturday	06:30 to 16:00
3.8.8.3	Validity period of authorisation	3 Months
3.8.8.4	Non-use period	1 Months
3.8.8.5	Gateway Device restriction	Turnstile only, unless driver, then Gate



3.8.8.6	Escort or vehicle access restriction	Vehicular access on Estate only
3.8.8.7	Single entry/exit restriction	None
3.8.9	Estate Agents	
3.8.9.1	Day restrictions	None
3.8.9.2	Hour restrictions	07:00 to 19:00
3.8.9.3	Validity period of authorisation	Annual accreditation renewal required by 31 March
3.8.9.4	Non-use period	2 Months
3.8.9.5	Gateway Device restriction	Booms only
3.8.9.6	Escort or vehicle access restriction	Vehicular access on Estate only
3.8.9.7	Single entry/exit restriction	None
3.8.10	Visitors (day)	
3.8.10.1	Day restrictions	None
3.8.10.2	Hour restrictions	None
3.8.10.3	Validity period of authorisation	24 Hours from time of entry
3.8.10.4	Non-use period	Not applicable
3.8.10.5	Gateway Device restriction	Booms or Gate only
3.8.10.6	Escort or vehicle access restriction	Vehicular access on Estate only
3.8.10.7	Single entry/exit restriction	Yes – one entry and one exit
3.8.11	Extended Stay Visitors	
3.8.11.1	Day restrictions	None
3.8.11.2	Hour restrictions	None
3.8.11.3	Validity period of authorisation	Until 24:00 (midnight) on the last day authorised, with a maximum of 10 days
3.8.11.4	Non-use period	Not applicable
3.8.11.5	Gateway Device restriction	Booms or Gate only
3.8.11.6	Escort or vehicle access restriction	Vehicular access on Estate only
3.8.11.7	Single entry/exit restriction	None
3.8.12	Visitors (arranged by Estate Agent)	
3.8.12.1	Day restrictions	None
3.8.12.2	Hour restrictions	07:00 to 19:00
3.8.12.3	Validity period of authorisation	Not applicable
3.8.12.4	Non-use period	Not applicable
3.8.12.5	Gateway Device restriction	Booms or Gate only
3.8.12.6	Escort or vehicle access restriction	Visitors that gain access to the Estate , which access was arranged by an Estate Agent , must be accompanied at all times by the Estate Agent while on the Estate . The Estate Agent may do so in his/her vehicle while the Estate Agent's Visitor may be in their vehicle. Vehicular access on Estate only
3.8.12.7	Single entry/exit restriction	Yes – one entry and one exit

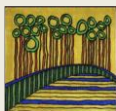

3.8.13 Temporary Contractors

3.8.13.1	Day restrictions	Sundays and Public Holidays
3.8.13.2	Hour restrictions	
3.8.13.2.1	Work Day	07:30 to 17:30
3.8.13.2.2	Saturday	07:30 to 16:00
3.8.13.3	Validity period of authorisation	Hour restriction as the case might be
3.8.13.4	Non-use period	Not applicable
3.8.13.5	Gateway Device restriction	Turnstile only, unless driver, then Gate
3.8.13.6	Escort or vehicle access restriction	Vehicular access on Estate only
3.8.13.7	Single entry/exit restriction	Yes – one entry and one exit

3.8.14 Delivery Contractors

3.8.14.1	Day restrictions	Sundays and Public Holidays
3.8.14.2	Hour restrictions	
3.8.14.2.1	Work Day	07:30 to 17:30
3.8.14.2.2	Saturday	07:30 to 16:00
3.8.14.3	Validity period of authorisation	2 Hours
3.8.14.4	Non-use period	Not applicable
3.8.14.5	Gateway Device restriction	GateBook Device managed - then Gate
3.8.14.6	Escort or vehicle access restriction	Vehicular access on Estate only
3.8.14.7	Single entry/exit restriction	Yes – one entry and one exit
3.8.14.8	Shuttle delivery (multiple entries)	Access Arranger to arrange with Estate Management

3.8.15 Recurring Contractors

3.8.15.1	Day restrictions	Sundays and Public Holidays
3.8.15.2	Hour restrictions	
3.8.15.2.1	Work Day	07:30 to 17:30
3.8.15.2.2	Saturday	No access
3.8.15.3	Validity period of authorisation	3 Months
3.8.15.4	Non-use period	1 Month
3.8.15.5	Gateway Device restriction	Turnstile only, unless driver, then Gate
3.8.15.6	Escort or vehicle access restriction	Vehicular access on Estate only
3.8.15.7	Single entry/exit restriction	None

3.8.16 Casuals

3.8.16.1	Day restrictions	Sundays and Public Holidays None for Residents and Tenants
3.8.16.2	Hour restrictions	07:30 to 17:30
3.8.16.2.1	Work Day	07:30 to 16:00
3.8.16.2.2	Saturday, Sunday and Public Holidays	Hour restriction as the case might be
3.8.16.3	Validity period of authorisation	Not applicable
3.8.16.4	Non-use period	Turnstile only
3.8.16.5	Gateway Device restriction	Must be escorted by Access Arranger
3.8.16.6	Escort or vehicle access restriction	Yes – one entry and one exit
3.8.16.7	Single entry/exit restriction	



3.8.17 Furniture Delivery Contractors

3.8.17.1	Day restrictions	Sundays and Public Holidays
3.8.17.2	Hour restrictions	07:30 to 20:00
3.8.17.3	Validity period of authorisation	For the day of issue
3.8.17.4	Non-use period	Not applicable
3.8.17.5	Gateway Device restriction	GateBook Device managed - then Gate
3.8.17.6	Escort or vehicle access restriction	Vehicular access on Estate only
3.8.17.7	Single entry/exit restriction	Yes – one entry and one exit
3.8.17.8	Shuttle delivery (multiple entries)	Access Arranger to arrange with Estate Management

3.8.18 Food Deliverers

3.8.18.1	Day restrictions	None
3.8.18.2	Hour restrictions	07:30 to 20:30
3.8.18.3	Validity period of authorisation	15 minutes
3.8.18.4	Non-use period	Not applicable
3.8.18.5	Gateway Device restriction	GateBook Device managed - then Gate
3.8.18.6	Escort or vehicle access restriction	No escort – Only vehicular access
3.8.18.7	Single entry/exit restriction	Yes – one entry one exit
3.8.18.8	Shuttle delivery (multiple entries)	Not allowed

3.9 “**Access Procedure**” means the process followed by a **Security Officer** to grant access to an **Irregular Entrant**, it being recorded that all steps are mandatory, namely:

3.9.1 The **Security Officer** will determine whether the person arriving at the **Gatehouse** is an authorised **Irregular Entrant**.

3.9.2 The **Security Officer** will request the **Irregular Entrant** to provide him with the **Preauthorisation Code**.

3.9.3 By utilising the **GateBook Device**, the **Security Officer** will search for the **Preauthorisation Code**, and when found and if valid, will establish that the visit has been authorised.

3.9.4 The **Security Officer** will request the driver to provide him with a valid driver’s licence. Expired driver’s licences are acceptable, but photocopies of driver’s licences or obvious forgeries thereof are not acceptable.

3.9.5 The **Security Officer** will scan the driver’s licence and the vehicle’s licence disc, which scan will record details of the **Irregular Entrant** and the vehicle in **GateBook** for purposes of identifying the person gaining entry onto the **Estate**.

3.9.6 The **Security Officer** will then scan a **Temporary Access Card** and hand the **Temporary Access Card** to the **Irregular Entrant**.

3.9.7 Once the **Temporary Access Card** is scanned with the **GateBook Device** the **Gateway Device** will automatically open.

3.9.8 To exit the **Estate**, the **Irregular Entrant** must hand the **Temporary Access Card** to the **Security Officer** who will again scan the **Temporary Access Card** with the **GateBook Device** which will cause the **Gateway Device** to open. The **Security Officer** will retain the **Temporary Access Card**.



- 3.9.9 **Extended Stay Visitors** receive a **Temporary Access Card** that will allow repeated entries/exits. During the extended stay period, the **Extended Stay Visitor** would need to present the **Temporary Access Card** to the **Security Officer** to exit – if returning, the **Security Guard** will immediately return the **Temporary Access Card** to the **Extended Stay Visitor**. Once the period for which the **Access Arranger** has arranged access for the **Extended Stay Visitor** to the **Estate** has expired, or once the **Extended Stay Visitor** exits the Estate for the last time for that particular extended visit, the **Extended Stay Visitor** must return the **Temporary Access Card** to the **Security Officer** when exiting the Estate.
- 3.9.10 Different **Access Procedures** apply to passengers on vehicles of **Temporary Contractors**, **Delivery Contractors** and **Casuals** - see **Temporary Registration Process** below.
- 3.10 “**ACCS**” means the **Association’s** Access Control Computer System found at the **Gatehouse**.
- 3.11 “**Architect**” means the Architectural entity appointed by the **Developer** and the **Association**.
- 3.12 “**Association**” means Port Zimbali Estate Home Owners’ Association (NPC).
- 3.13 “**Authorised Resident**” means a **Member** authorised by the **Primary Resident** to be an **Access Arranger** or a **Tenant** authorised by the **Primary Tenant** to be an **Access Arranger**.
- 3.14 “**Authorised Access Arranger**” means individuals that may arrange access for a **Regular Entrant** by following the **Take-on Process**, such individuals being limited to the following:
- 3.14.1 **Owner**.
- 3.14.2 **Authorised Tenant** once authorised by the **Owner**, which means the **Owner** following and successfully completing the **Take-on Process** for the **Tenant**.
- 3.14.3 **Developer**.
- 3.14.4 **Main Contractor** Management Official.
- 3.14.5 **Managing Agent**.
- 3.14.6 **Estate Management**.
- 3.15 “**Casuals**” are defined as follows:
- 3.15.1 Individuals arriving on foot at the **Gatehouse** seeking to gain access to the **Estate** as a result of an **Access Arranger** entering into a temporary working arrangement with such individual.
- 3.15.2 Access can only be arranged for such individual on receipt of a personal request from an **Access Arranger**, the nature of such personal request to be the physical presence of the **Access Arranger** at the **Gatehouse** arranging such access with the **Security Officers**.
- 3.15.3 The **Security Officer** will require **Positive Identification** from the **Casual** so that the **Casual’s** personal information can be captured directly into the **GateBook Device**, thus registering temporary access for the **Casual** as an **Irregular Entrant** onto the **Estate**.



- 3.15.4 The **Access Arranger** must personally escort the **Casual** to the **Property** where the **Casual** will be working, and when the work is completed the **Access Arranger** must personally escort the **Casual** to the **Gatehouse** where the **Casual** will exit the **Estate**.
- 3.15.5 A **Casual** may only be present on the **Property** in question.
- 3.15.6 Should the said temporary working arrangement evolve into a more permanent arrangement, the **Access Arranger** must make arrangements for the **Casual** to be registered as a **Domestic**.
- 3.16 "**Controlled Flow System**" means a setting in the **ACCS**, as elected by the **Association**, whereby the **ACCS** will not allow two similar **Access Events** to follow on each other – for example: if a **Permanent Access Card** bearer enters the **Estate** the bearer must first exit the **Estate** before such bearer can enter again. The **Controlled Flow System** does not apply to **Regular Entrants**.
- 3.17 "**Delivery Contractors**" are defined as follows:
- 3.17.1 **Delivery Contractor** means a service provider delivering supplies, materials and/or goods to the **Estate** at the request of an **Access Arranger**.
- 3.17.2 For purposes of the **Security Policy**, **Delivery Contractors** are viewed and dealt with as **Irregular Entrants**, taking into account that their passengers must follow the **Temporary Registration Process**.
- 3.17.3 They are defined as formalised businesses that arrive at the **Gatehouse** in a dedicated/distinguishable vehicle.
- 3.17.4 They require no more than 2 hours to effect the relevant delivery to the **Property** in question.
- 3.17.5 Escorting of a **Delivery Contractor** is not required, but on condition that **Delivery Contractors**, including their staff and workers, gain access onto the **Estate** in and on a vehicle.
- 3.17.6 Owing to restrictions insofar as the size and other limitations placed on delivery vehicles that may gain access to the **Estate**, shuttle deliveries utilising smaller vehicles that are allowed onto the **Estate** takes place. The **Access Arranger** must contact **Estate Management** so that special access arrangements can be made for such shuttle deliveries, taking into account where the disallowed delivery vehicle may park during the delivery process.
- 3.17.7 Impact of delivery vehicle limitations
- 3.17.7.1 If the delivery vehicle meets the criteria set to gain access onto the **Estate** the driver of the vehicle, subject to the **Access Authorisation Process**, is issued with a **Temporary Access Card**.
- 3.17.7.2 If the delivery vehicle DOES NOT meet the criteria set to gain access onto the **Estate** the driver of the shuttle vehicle of the **Delivery Contractor**, subject to the **Access Authorisation Process**, is issued with a **Multiple Entry Access Card**.
- 3.17.7.3 Notwithstanding delivery vehicle limitations, to gain access onto the **Estate**, the passengers and/or staff of the **Delivery Contractor** are subject to the **Temporary Registration Process**.



- 3.17.8 Pedestrians arriving at the **Gatehouse** will not qualify as a **Delivery Contractor** and will be dealt with in terms of the policy relating to **Casuals**.
- 3.18 "**Developer**" means Viking Pony Properties 37 (Pty) Ltd, its officials and appointed consultants.
- 3.19 "**Domestic**" means the following:
- 3.19.1 An individual arriving on foot at the **Gatehouse** and gaining access to the **Estate** as a result of a **Resident** registering the individual as a **Regular Entrant** (a "**Domestic**") on the **ACCS** by following **Take-On Process**.
- 3.19.2 Once inside the **Estate**, **Domestics** may walk to the **Property** of the subject **Resident** as escorting is not required.
- 3.19.3 **Domestics** are categorised into two categories:
- 3.19.3.1 **Domestics** that work for single days at a time (entry to and exit from the **Estate** takes place daily);
- 3.19.3.2 **Live-in Domestics** that overnight on the **Property** of the **Resident**.
- 3.19.4 Each category of **Domestic** is subject to its own set of **Access Parameters**.
- 3.20 "**Estate**" means Port Zimbali Estate.
- 3.21 "**Estate Agent**" means an agent of a recognised Estate Agency as defined and accredited in terms of the RULES of the Association.
- 3.22 "**Estate Management**" means an Estate Manager employed by the Board of Directors in a Managerial capacity or a Director of the Board of Directors nominated as Portfolio Director to oversee the day-to-day affairs of the **Association**.
- 3.23 "**Extended Stay Visitor**" means a **Visitor** as defined herein, except that an **Extended Stay Visitor** has access to the **Estate** for more than 24 Hours, which is the case for a normal **Visitor**, and the fact that ONLY an **Authorised Resident** can authorise **Extended Stay Visitor** access, the maximum period for such extended stay being 10 consecutive days.
- 3.24 "**Food Deliverers**" are defined as follows:
- 3.24.1 **Food Deliverer** means a service provider delivering prepared food (i.e. take away food) to the **Estate** at the request of an **Access Arranger**.
- 3.24.2 For purposes of the **Security Policy**, **Food Deliverers** are viewed and dealt with as **Irregular Entrants**.
- 3.24.3 They are defined as formalised businesses that arrive at the **Gatehouse** in a dedicated/distinguishable vehicle, which vehicle may be a motorcycle, but not a bicycle.
- 3.24.4 They require no more than 15 minutes to effect the relevant delivery to the **Property** in question.
- 3.24.5 Escorting of a **Food Deliverer** is not required, but on condition that **Food Deliverers**, gain access onto the **Estate** in and on a vehicle.



- 3.24.6 Pedestrians arriving at the **Gatehouse** will not qualify as a **Food Deliverer** and will be dealt with in terms of the policy relating to **Casuals**.
- 3.25 "**Furniture Delivery Contractors**" means **Temporary Contractors** as defined herein, except for the following:
- 3.25.1 They may be on the **Estate** for periods longer than 2 hours, but must exit the **Estate** before 20:00 on the day that they gained entry onto the **Estate**.
- 3.25.2 Owing to restrictions placed on furniture delivery vehicles that may gain access to the **Estate**, shuttle deliveries utilising smaller vehicles that are allowed onto the **Estate** takes place. The **Access Arranger** must contact **Estate Management** so that special access arrangements can be made for such shuttle deliveries, taking into account where the disallowed furniture delivery vehicle may park during the furniture removal process.
- 3.25.3 Impact of furniture delivery vehicle limitations
- 3.25.3.1 If the furniture delivery vehicle meets the criteria set to gain access onto the **Estate** the driver of the vehicle, subject to the **Access Authorisation Process**, is issued with a **Temporary Access Card**.
- 3.25.3.2 If the furniture delivery vehicle DOES NOT meet the criteria set to gain access onto the **Estate** the driver of the shuttle vehicle of the **Furniture Delivery Contractor**, subject to the **Access Authorisation Process**, is issued with a **Multiple Entry Access Card**.
- 3.25.3.3 Notwithstanding furniture vehicle limitations, to gain access onto the **Estate**, the passengers and/or staff of the **Furniture Delivery Contractor** are subject to the **Temporary Registration Process**.
- 3.25.4 Escorting of a **Furniture Delivery Contractors** is not required, but on condition that **Furniture Delivery Contractors**, including their staff and workers, gain access onto the **Estate** in and on a vehicle.
- 3.26 "**Gate**" means the contractor's gate.
- 3.27 "**GateBook**" means the visitor management system implemented by the **Association** to manage the **Access Events** of **Irregular Entrants** at the **Gatehouse**. It entails a Smart Phone application (the **GateBook App**) that must be downloaded onto the cellular phone. The administration of **GateBook** is internet based.
- 3.28 "**GateBook App**" means a Smart Phone Application that must be downloaded onto the cellular phone of every **Access Arranger**, to be utilised by the **Access Arranger** to generate a **Preauthorisation Code** which will be required by the **Security Officer** before they may grant access to an **Irregular Entrant** onto the **Estate**.
- 3.29 "**GateBook Device**" means a hand held device found at the **Gatehouse** and utilised by the **Security Officers** to manage the **Access Events** of **Irregular Entrants**.
- 3.30 "**Gatehouse**" means the building found at the entrance to the **Estate** which houses the **ACCS** and where the **Gateway Devices** and **Gateway Device Readers** can be found.
- 3.31 "**Gateway Device**" means any of the booms, the turnstile or the **Gate**.
- 3.32 "**Gateway Device Reader**" means the scanning devices situated at the **Gateway Devices**. Scanning an authorised **Temporary Access Card**, **Permanent Access Card**, **Registered**



Access Card or registered fingerprint on a **Gateway Device Reader** will open the relevant **Gateway Device**.

- 3.33 “**Identity Document**” means a valid RSA Identity Book, or a valid RSA Identity Card or a valid RSA Driver’s Licence. Expired driver’s licences are acceptable, but photocopies of driver’s licences or obvious forgeries thereof are not acceptable.
- 3.34 “**Irregular Entrant**” means a person, not registered on the **ACCS** via the **Take-On Process**, but requiring access to the **Estate**. **Security Officers** will require **Access Authorisation** before they may grant access to such persons. **Access Authorisation** can only be provided by an **Access Arranger**. The following persons are categorised as **Irregular Entrants**:
- 3.34.1 **Visitors**
- 3.34.2 **Delivery Contractors**
- 3.34.3 **Temporary Contractors**
- 3.34.4 **Casuals**
- 3.34.5 **Food Deliverers**
- 3.35 “**Live-in Domestic**” is defined under **Domestic**.
- 3.36 “**Main Contractor**” means:
- 3.36.1 The Dedicated Building Contractor, an entity consisting of management officials and staff, appointed by the **Association** in terms of paragraph 7 of the Community Participation Rules section of the **Rules**.
- 3.36.2 The Landscaping Service Provider, an entity consisting of management officials and staff, appointed by the **Association** in terms of paragraph 5.5 of the Community Participation Rules section of the **Rules**.
- 3.36.3 The electric fence maintenance service provider, an entity consisting of management officials and staff, appointed by the **Association**.
- 3.36.4 The **Developer**.
- 3.36.5 The **Architect**.
- 3.36.6 The **Security Service Provider**, an entity consisting of management officials and **Security Officers**, appointed by the **Association**.
- 3.36.7 **Estate Management** appointed by the **Association**. Regarded as a **Main Contractor** for purposes of appointing **Recurring Contractors**.
- 3.36.8 An **Owner**, when such **Owner** needs to employ a **Subcontractor** to do work that will take longer than 5 days at his **Property**.
- 3.37 “**Managing Agent**” means Financial Services Providers (Pty) Ltd, represented by its Management Officials or appointed agents.
- 3.38 “**Member**” means an **Owner** of a **Unit** residing on the **Estate**, including his residing family members and/or other permanent residents, but excluding Live-in Domestic when applicable.



- 3.39 "MOI" means the Memorandum of Incorporation of the **Association**, which includes the **RULES** of the **Association**.
- 3.40 "**Multiple Entry Access Card**" means a **Multiple Entry Access Card**, pre-printed for recognition as a **Multiple Entry Access Card** belonging to the **Association**, which card will be handed to the driver of a **Furniture Delivery Contractor** by a **Security Officer** for use on a **Gateway Device Reader** to open a **Gateway Device** if authorised, but within the **Access Parameters** applicable to the category of **Furniture Delivery Contractor**. **Multiple Entry Access Cards** handed to **Furniture Delivery Contractors** remain the property of the **Association** and must always be returned to the **Security Officers**, failing which the cost thereof will be recovered from the **Access Arranger** via the **Association's** monthly billing system.
- 3.41 "**Owner**" means a person owning a **Unit** in the **Estate**, whether directly or whether via holding an executive position in a juristic entity if such juristic entity is the **Owner**.
- 3.42 "**Pedestrian**" means a person seeking access to the **Estate**, and once inside the **Estate** to be on foot. Other than a **Domestic**, a **Pedestrian** can only gain access if the **Pedestrian** is a **Resident** and may access the **Estate** via the **Gateway Device** (ONLY the turnstile) by scanning his finger print at the **Gateway Device Reader**, implying that such **Pedestrian** must be registered on the **ACCS** via the **Take-On Process**. This Rule also applies to children arriving on foot seeking access to the **Estate**. Under no circumstances may a **Pedestrian** gain entry to the **Estate** if not through the turnstile (**Gateway Device**).
- 3.43 "**Permanent Access Card**" means a **Permanent Access Card** issued to a **Domestic** of a **Resident** or a staff member of a **Regular Entrant** on a permanent basis for use on a **Gateway Device Reader** to open a **Gateway Device** if authorised, but within the **Access Parameters** applicable to the relevant category of **Domestic** or staff member of the **Regular Entrant**. The **Permanent Access Card** is pre-printed for recognition as a **Permanent Access Card** belonging to the **Association** and is personalised with the **Permanent Access Card** holder's photograph, name and ID number. A **Permanent Access Card** is intended for use in instances where the **Gateway Device Reader** is unable to recognise the finger print of the individual in question. **Permanent Access Cards** are subject to the **Controlled Flow System**. **Permanent Access Cards** so issued remain the property of the **Association**, it being recorded that the replacement cost thereof will be recovered from the **Resident** or **Regular Entrant** via the **Association's** monthly billing system.
- 3.44 "**Positive Identification**" means presentation of an **Identity Document**. In the event that the individual for whom identification is required is a foreigner and therefore NOT in possession of an **Identity Document**, the individual must present his/her valid passport (a passport is invalid if it has expired). If such individual is a **Food Deliverer**, **Temporary Contractor**, a **Delivery Contractor** or a **Casual**, the passport must be accompanied by a current/valid work permit issued by the Department of Home Affairs.
- 3.45 "**Primary Resident**" means the **Owner** or a person selected by the **Owner** to be the individual who will approve the requests by an individual residing on the **Property** to become an **Access Arranger**.
- 3.46 "**Primary Tenant**" means a person, selected by the person that entered into a valid lease agreement with an **Owner** to be the individual who will approve the requests by an individual residing on the **Property** to become an **Access Arranger**.



- 3.47 “**Preauthorisation Code**” means a 4-digit number that an **Access Arranger** will receive on their Cellular Phone via the **GateBook App** after a request for a **Preauthorisation Code** has been submitted, such **Preauthorisation Code** only being valid for the day for which it was requested.
- 3.48 “**Property**” means the Erf situated in the **Estate** that is owned by the **Owner**.
- 3.49 “**Recurring Contractors**” are defined as follows:
- 3.49.1 **Recurring Contractors** means a service provider providing a service at more than one specific **Property** on the **Estate** at the request of an **Authorised Resident**, the nature of such service being repetitive in nature and relating to services such as swimming pool maintenance and window cleaning.
- 3.49.2 **Recurring Contractors** are registered as **Subcontractors** appointed by **Estate Management** and as a result are viewed as **Regular Entrants** requiring a **Take-on Process**.
- 3.49.3 They are defined as formalised businesses that arrive at the **Gatehouse** in a dedicated/distinguishable vehicle.
- 3.49.4 “**Registered Access Card**” means a **Registered Access Card**, pre-printed for recognition as a **Registered Access Card** belonging to the **Association**, but the **Registered Access Card** is also personalised as it will bear the photo and personal details of the specific **Resident** it is issued to. A **Registered Access Card** is intended for use in instances where the **Gateway Device Reader** is unable to recognise the finger print of the **Resident** in question.
- 3.49.5 **Pedestrians** arriving at the **Gatehouse** will not qualify as **Recurring Contractors** and will be dealt with in terms of the policy relating to **Casuals**.
- 3.50 “**Regular Entrant**” means a person, registered on the **ACCS** via the **Take-On Process**, granting such person access to the **Estate** when activating an **Access Event** on a **Gateway Device Reader**. The following persons are categorised as **Regular Entrants**:
- 3.50.1 **Residents**.
- 3.50.2 **Domestics** – Daily and Live-in Domestic.
- 3.50.3 **Main Contractors** – Management and staff.
- 3.50.4 **Subcontractors** – Management and staff.
- 3.50.5 **Estate Agents**.
- 3.50.6 **Recurring Contractors**.
- 3.50.7 **Security Service Provider** – Management and **Security Officers**.
- 3.51 “**Residents**” means both **Members** and **Tenants** as defined herein.
- 3.52 “**RULES**” mean the **RULES** of the **Association** as contained in the **MOI** of the **Association**.

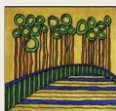

- 3.53 "Security Service Provider" means the service provider contracted to the **Association** to manage the security related affairs of the **Association**, represented by its Management Official.
- 3.54 "Security Officers" mean the individuals employed by the **Security Service Provider** tasked with managing the **Gatehouse** from a security perspective as prescribed by the **Security Policy** and in line with the protocols set by the **Security Service Provider**.
- 3.55 "Security Policy" means this section of the **RULES** styled "Security Policy and Procedures of the **Association**".
- 3.56 "**Subcontractors**" are defined as follows:
- 3.56.1 Entities consisting of management officials and staff, and are defined as formalised businesses that arrive at the **Gatehouse** in a dedicated vehicle.
- 3.56.2 **Subcontractors** may only be employed by a **Main Contractor**, or a **Member** or **Estate Management**, as the **ACCS** requires **Subcontractors** to be "linked" to the entity that employed them, being a **Main Contractor**, or a **Member** or **Estate Management**.
- 3.56.3 **Subcontractors** are subject to the **RULES** pertaining to **Regular Entrants**, thus requiring a **Take-On Process** to be followed.
- 3.56.4 **Subcontractors** are registered on the **ACCS** in a manner that they have access to the **Estate** on a regular basis subject to the **RULES** defined for **Subcontractors**, within the applicable **Access Parameters**.
- 3.56.5 Pedestrians arriving at the **Gatehouse** will not qualify as a **Subcontractor** and will be dealt with in terms of the policy relating to **Casuals**.
- 3.57 "**Take-On Process**" means the following procedures that must be followed for an individual to be registered as a **Regular Entrant** on the **ACCS**:
- 3.57.1 The **Authorised Access Arranger** must complete, sign and provide the relevant **Access Application Form**, together with the required supporting documentation to **Estate Management**. The details of every **Regular Entrant** for whom regular access is required must be provided on the relevant **Access Application Form**.
- 3.57.2 **Estate Management** verifies the form and documentation and, if found acceptable, will input the details of the **Regular Entrant** found on the form into the **ACCS**.
- 3.57.3 An invitation for fingerprint capturing and registration on the **ACCS**, which must take place at the **Gatehouse**, will be extended to the **Regular Entrant**, where after the **Regular Entrant** will be able to access the **Estate** within the **Access Parameters** set for the applicable **Regular Entrant** category.
- 3.58 "**Temporary Access Card**" means a **Temporary Access Card**, pre-printed for recognition as a **Temporary Access Card** belonging to the **Association**, which card will be handed to an **Irregular Entrant** by a **Security Officer** for use on a **Gateway Device Reader** to open a **Gateway Device** if authorised, but within the **Access Parameters** applicable to the category of **Irregular Entrant**. **Temporary Access Cards** handed to **Irregular Entrants** remain the property of the **Association** and must always be returned to the **Security Officers**, failing which the cost thereof will be recovered from the **Access Arranger** via the



Association's monthly billing system. **Temporary Access Cards** are subject to the **Controlled Flow System**.

- 3.59 "Temporary Contractors" are defined as follows:
- 3.59.1 **Temporary Contractor** means a service provider providing a service at a specific Property on the **Estate** at the request of an **Access Arranger**, the nature of such service relating to the repairs, maintenance, construction and/or installation of new or removal of old property infrastructure, additions, alterations, and the like.
- 3.59.2 The **Access Arranger** is obliged to meet the obligations placed on him in terms of paragraph 15.3 of the Community Participation Rules section of the **RULES**, styled "Construction and/or Installation Clearance Certificate", before arranging access for a **Temporary Contractor** onto the **Estate**.
- 3.59.3 For purposes of the **Security Policy**, **Temporary Contractors** are viewed and dealt with as **Irregular Entrants**, taking into account that their staff members must follow the **Temporary Registration Process**.
- 3.59.4 **Temporary Contractors** are contractors that require a period of no more than 5 (five) days to fulfil their duties and contractual obligations at the **Property** for which they have been employed.
- 3.59.5 Escorting of **Temporary Contractors** is not required, but on condition that **Temporary Contractors**, including their staff and workers, gain access onto the **Estate** in and on a vehicle.
- 3.59.6 They are defined as formalised businesses that arrive at the **Gatehouse** in a dedicated/distinguishable vehicle.
- 3.59.7 Pedestrians arriving at the **Gatehouse** will not qualify as a **Temporary Contractor** and will be dealt with in terms of the policy relating to **Casuals**.
- 3.60 "**Temporary Registration Process**" means the process **Irregular Entrants** must follow to gain access to the **Estate** in instances when such **Irregular Entrant** is a passenger, worker or staff member of a **Delivery Contractor** or a **Temporary Contractor** or when the **Irregular Entrant** is a **Casual**. The **Temporary Registration Process** is as follows:
- 3.60.1 The **Temporary Registration Process** DOES NOT apply to **Visitors**.
- 3.60.2 **Delivery Contractor / Temporary Contractor**
- 3.60.2.1 The Drivers of the vehicles of **Delivery Contractors** and/or **Temporary Contractors** gain access to the Estate by following the **Access Authorisation Process**.
- 3.60.2.2 The passengers concerned will disembark the vehicle.
- 3.60.2.3 **Positive identification** is required.
- 3.60.2.4 By utilising the **GateBook Device**, the **Security Officer** will register the passenger with **GateBook** by taking a photo of the individual, taking a photo of the individual's **Identity Document** or valid passport and thereafter scanning the bar-code found on the individual's **Identity Document** or valid passport. This process will be repeated for however number of passengers requires access to the **Estate**.
- 3.60.2.5 Once all passengers have been registered on **GateBook**, they may embark the vehicle and access the **Estate** with the driver of the vehicle.



- 3.60.2.6 Upon exiting the **Estate** the subject passengers will disembark the vehicle before it exits the **Estate**. The passenger will present his/her **Identity Document** to the **Security Officer** for scanning, where after the vehicle must exit the **Estate**.
- 3.60.3 **Casuals**
- 3.60.3.1 **Positive identification** is required.
- 3.60.3.2 By utilising the **GateBook Device**, the **Security Officer** will register the **Casual** with **GateBook** by taking a photo of the individual, taking a photo of the individual's **Identity Document** or valid passport and thereafter scanning the bar-code found on the individual's **Identity Document** or valid passport.
- 3.60.3.3 The **Security Officer** will contact the relevant **Access Arranger** to fetch the **Casual** as **Casuals** must be escorted by the relevant **Access Arranger** onto the Estate.
- 3.61 "**Tenant**" means a person, whether directly or whether via holding an executive position in a juristic entity if such juristic entity is the **Tenant** that resides on the **Estate** as a result of the **Tenant** entering into a valid lease agreement with an **Owner**, including their residing family members and/or other permanent residents (excluding Live-in Domestic).
- 3.62 "**Unit**" means the **Property**.
- 3.63 "**Visitor**" means any of the persons defined as follows:
- 3.63.1 Persons visiting a **Resident**, which includes their passengers present in the same vehicle, whether the visit is for a once-off visit or for an extended stay visit.
- 3.63.2 Should a **Visitor** seek access to the **Estate** as a **Pedestrian** such **Visitor** must be fetched by the **Resident** personally in the relevant **Resident's** vehicle. Such **Visitor** is therefore not allowed to enter the **Estate** as a **Pedestrian**.
- 3.63.3 Persons invited by an **Estate Agent** to view a property that is listed as being for sale, arriving in their own vehicle, and which includes their travelling party present in the same vehicle.
- 3.64 "**Website**" means the **Website** of the **Association** (www.pze.co.za).
- 3.65 "**Work Day**" means any Monday, Tuesday, Wednesday, Thursday or Friday, as long as such day is not a recognised South African Public Holiday.



PORT ZIMBALI ESTATE HOME OWNERS' ASSOCIATION (NPC)

CLUBHOUSE POLICY

1. INTRODUCTION

- 1.1 One of the main objectives of the Association is the provision of a safe, secure, equitable and high quality lifestyle for residents. The powers given to the Directors by the Memorandum of Incorporation to create and implement RULES, is for the protection of this objective on the Estate.
- 1.2 Quality and harmonious community living is achieved when members use and enjoy communal areas, such as the Clubhouse of the Estate, in a manner which enables other members the use and enjoyment of the Clubhouse on a similar basis. General consideration of all members for each other will greatly assist in achieving a happy community.
- 1.3 In summary: the Clubhouse, and all it has to offer, is there primarily for members to enjoy – the basic neighbourly rule being that one should leave the Clubhouse and its surrounds as one would like to find it.
- 1.4 In this Clubhouse Policy, if the content of an item or paragraph so dictates, reference to a Member will be deemed to include –
 - 1.4.1 an individual in his/her capacity as the registered owner of a unit on the Estate, or in his/her capacity as the legal representative (such representative being a Partner, a Member, a Director/Shareholder or a Trustee, as the case might be) of the registered owner (such owner being a Partnership, a Close Corporation, a Private Company or a Trust, as the case might be) of a unit on the Estate;
 - 1.4.2 a tenant in possession of a reigning Tenant Clearance Certificate is regarded as a Member for booking purposes.
 - 1.4.3 the member's guests and visitors, on condition the member is also present;
 - 1.4.4 the tenant's guests and visitors, on condition the tenant is also present.

2. GENERAL

- 2.1 Members utilising the Clubhouse, do so at their sole risk.

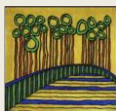

- 2.2 The Association shall not be liable for any injury, loss or damage, caused to any Member utilising the Clubhouse, the Playground and the Playground facilities or any part thereof, its equipment or facilities arising from any cause whatsoever, including, but not limited to the negligence of the Association and its Directors, the Club and its Committee Members, as well as any servants, agents or appointees of either the Association or the Club.
- 2.3 Members unreservedly agree to abide by the RULES of the Association and the Clubhouse Policy contained herein. Should a Member fail or refuse to comply with the RULES and the Clubhouse Policy, the Association may take whatever action necessary and appropriate in the circumstances and recover from the Member any cost incurred in taking such action without prejudice to its rights to recover any fines or other penalties imposed.
- 2.4 Usage of the Clubhouse is restricted to Members, but on the strict condition that the Member's Association account is completely up to date.
- 2.5 Non-residents may only use the Clubhouse as guests at functions which are hosted by a Member, it being recorded that such non-residents are limited to being on the premises of the Clubhouse only.
- 2.6 The Directors reserve the right to amend these Policies at regular intervals, it being recorded that such amendments will always be in the best interests of the Association and its Members.

3. **SOCIAL CLUB AND SOCIAL CLUB COMMITTEE**

- 3.1 Members of the Association by virtue of their Membership of the Association are also Members of the Social Club.
- 3.2 A Social Club Committee is responsible for managing the affairs and for achieving the objectives of the Social Club.
- 3.3 Social Club Committee Members are elected annually from the Members of the Association at the Annual General Meetings of the Association, it being recorded that the Social Club Committee may exercise a right to approach additional Members to assist with its functions, should additional assistance be required before the next Annual General Meeting.
- 3.4 The principal objective of the Social Club Committee is to promote social and recreational events for Members and to this end to provide, encourage, support and organise sports, recreation, cultural and social events and activities, of a non-political and a non-religious nature, as approved by the Association, from time to time.

4. **USAGE OBJECTIVES**

- 4.1 Primary usage objectives
- 4.1.1 Community Centre activities for Members
- 4.1.1.1 Celebrating Festive Occasions (i.e. Old Year's Eve, Valentine's Day, etc.)
- 4.1.1.2 Social get-togethers (i.e. TV screenings, Games events, etc.)
- 4.1.1.3 Association presentations (i.e. Talks and Lectures on regional and local community affairs)
- 4.1.1.4 Club presentations (i.e. Talks on topics of interest such as Birding, Fauna & Flora, etc.)
- 4.1.1.5 Playground and playground facilities for children



- 4.1.1.6 Outdoor chess
- 4.1.1.7 Special interests (i.e. Yoga classes, Pilatus classes, Book clubs, Photography clubs, etc.)
- 4.1.1.8 Other similar activities

4.1.2 Business Centre activities for Members and the Association

- 4.1.2.1 Annual general meetings
- 4.1.2.2 General member meetings
- 4.1.2.3 Board meetings
- 4.1.2.4 Club committee meetings
- 4.1.2.5 Collective member meetings
- 4.1.2.6 Meetings with Service Providers
- 4.1.2.7 Marketing presentations
- 4.1.2.8 Meetings and/or functions specifically arranged by the Developer

4.2 Secondary usage objectives

The Clubhouse is available to be booked by Members for Private Functions.

5. **HONESTY BAR**

5.1 For the sole benefit of the Members of the Association the Social Club Committee has implemented an Honesty Bar in the Clubhouse, which implementation was approved by the Board of Directors of the Association.

5.2 An "Honesty Bar" means that a range of refreshments are available for the enjoyment of the Members when they visit the Clubhouse on the basis that the visiting Members will record the number and description of refreshments consumed during their visit to the Clubhouse in a Honesty Bar Register found at the Clubhouse, where after, on a monthly basis, the Social Club will recover the cost of the refreshments consumed from the visiting Members.

5.3 No alcoholic refreshments are available in the Honesty Bar for enjoyment by Members. Alcohol is however allowed on the Clubhouse premises, but only on condition Members provide their own alcohol and do so in a manner that complies with the relevant conditions found elsewhere in these Clubhouse Rules.

5.4 Members that have arrears levy accounts with the Association may not utilise the Honesty Bar – this also applies to the Tenants of Members that have arrears levy accounts with the Association, irrespective of whether the Tenants are up to date with the payment of their rental to their landlord Member.

5.5 Honesty Bar consumption during functions

5.5.1 Members that Book the Clubhouse for Private Functions may utilise the Honesty Bar subject to such Members making special arrangements with the Social Club Committee to cover the cost of refreshments consumed during the Private Function, it being recorded that the Member that made the Booking is responsible to cover the cost in question.

5.5.2 In the event that a Member has not Booked the Clubhouse, but has held a Private Function at the Clubhouse (where more than 10 outside visitors are present at the function), the Member that arranged the function is responsible to cover the cost of refreshments consumed.



5.5.3 In the event that a Member merely visits the Clubhouse with a smaller number of outside visitors (less than 10 outside visitors), the Member will also bear the responsibility for Honesty Bar consumption by such visitors.

6. **PRIVATE FUNCTION**

6.1 A function will be regarded as a Private Function when –

6.1.1 a Member formally makes a booking for private use by submitting a completed Application to book The Viking;

6.1.2 a Member, not having made a formal booking, uses The Viking for a function where more than 10 outside visitors (non-residents) are present at the function – this number excludes children under the age of 12 years old.

6.2 When a number of Members decide to gather and utilise The Viking, irrespective of whether such Members are accompanied by outside visitors, such gathering of individuals will not be regarded as a Private Function.

6.3 Children’s birthday parties will not be regarded as a Private Function as long as the said party activities remained outside the building, failing which it would be deemed to be a Private Function. In addition children’s parties must finish by 18:00 on the day, failing which, it will be deemed to be a Private function

7. **BOOKING THE CLUBHOUSE AND BOOKING FEES**

7.1 Booking fees ARE NOT payable for functions falling under the Primary usage objectives.

7.2 The Member and his/her guests have the sole use of the Clubhouse for Private Functions as from the date and time depicted on the Clubhouse booking form once approved by Estate Management, but specifically on the understanding that the Playground area IS NOT available for Private Functions.

7.3 A Private Function booking must be made by no later than 14 days before the envisaged function.

7.4 The Clubhouse MAY NOT be booked for a Private Function on Christmas Day (25 December), Day of Goodwill (26 December), Old Year’s Eve (31 December), New Year’s Day (1 January) or over Easter Weekend (as when these dates fall in a year – from Good Friday to Easter Monday).

7.5 The glasses, cutlery, crockery and other utensils of the Clubhouse will be made available to the Member for use at a Private Function if so requested by the member making the booking.

7.6 The storeroom WILL NOT be available for a Private Function, but the kitchen, including the fridge and the stoves, is available for use at a Private Function.

7.7 The under-counter fridge will NOT be emptied by Estate Management and the refreshments contained therein will remain in the under-counter fridge for the duration of the Private Function, it however being recorded that any consumption of beverages in the under-counter fridge will be for the account of the Member that made the booking.



- 7.8 At every instant that a Private Function is booked by a Member as contemplated herein, a Booking Fee is payable, it being recorded that the amount of the Booking Fee is published in the List of Levies, Fees, Charges and Recoveries published by the Association from time to time.
- 7.9 Children's birthday parties will not attract a Booking Fee unless the party is regarded as a Private Function.
- 7.10 Estate Management will confirm a private function booking to a Member in writing via e-mail, which confirmation will be utilised by the Managing Agent as an instruction by the Association to recover the Booking fee, and if applicable, any additional amount due from the Member via the next month's Member's levy account.
- 7.11 Cancellations
- 7.11.1 In the event of a Private Function booking being on a Saturday, a Sunday or a Public Holiday, and such booking being cancelled within 7 calendar days prior to the function date, the cancellation shall be subject to a Booking Fee Cancellation Charge of 50% of the Booking Fee.
- 7.11.2 Estate Management will confirm acceptance of a cancellation to a Member in writing via e-mail, which confirmation will be utilised by the Managing Agent as an instruction by the Association to recover the Booking Fee Cancellation Charge from the Member via the next month's Member's levy account.
8. **BOOKING THE CLUBHOUSE**
- 8.1 Application for a booking must be directed to Estate Management in writing by the Member (the "Applicant Member").
- 8.2 The application shall be made on the prescribed form (The Viking – Booking Application Form – herein after referred to as the "Booking Form"), which will include the following information:
- 8.2.1 The name, address and contact details of the Member applying for the booking;
- 8.2.2 The date and time of the intended function;
- 8.2.3 The purpose (e.g. birthday) and nature (e.g. spit braai) of the intended use of the Clubhouse;
- 8.2.4 The number of guests invited to the function (maximum of 60 persons, including children over the age of 6 years of age);
- 8.2.5 The number of vehicles of guests invited to the function (maximum 15 vehicles);
- 8.2.6 The number of tables (maximum 9) and chairs (maximum 36) required – excesses will be removed by the Association to storage prior to the function;
- 8.2.7 Description of any item that will be brought into the Clubhouse or onto playground not forming part of the current Clubhouse infra-structure or equipment (e.g. jumping castle).
- 8.3 The Association, at its sole discretion, shall have the right to refuse a booking application or limit the proposed use of the Clubhouse.



- 8.4 Estate Management will allocate and record all bookings in a calendar-type register on a “first-come-first-served” basis, such register being available for inspection to Members should they so require.
- 8.5 The Association, the Social Committee and the Developer are also obliged to make formal application to Estate Management for the booking of their events, with the exception that the Association, the Developer and the Social Committee are not subject to Booking Fees.
9. **HAND-OVER OF THE CLUBHOUSE**
- 9.1 On the date of the function and at a mutually agreed to pre-arranged time (such time to be at least 3 hours prior to the starting time of the function), Estate Management and the Applicant Member will meet at the Clubhouse for the hand-over of the Clubhouse (the “pre-event hand-over meeting”).
- 9.2 At the pre-event hand-over meeting the Applicant Member and Estate Management will record relevant information pertaining the state of the Clubhouse, its infrastructure and equipment on a hand-over form designed for this purpose - both the applicant Member and Estate Management will be obliged to co-sign a certificate of acceptance depicted on the hand-over form.
- 9.3 Once the hand-over form is signed, Estate Management will provide the Applicant Member with a set of keys to the Clubhouse, from which point on the Applicant Member will have sole access to the Clubhouse and will accept full responsibility for it.
- 9.4 On the morning after the function at a mutually agreed to pre-arranged time (such time to be by no later than 10:00), Estate Management and the Applicant Member will meet at the Clubhouse for the return hand-over (the “post-event hand-over meeting”).
- 9.5 At the post-event hand-over meeting the Applicant Member and Estate Management will once again record relevant information pertaining the post-event state of the Clubhouse, its infrastructure and equipment on the same hand-over form - both the applicant Member and Estate Management will be obliged to co-sign a certificate of acceptance depicted on the hand-over form.
- 9.6 A comparison of the information recorded on the hand-over form, pre-event vs post-event, will be done by the Applicant Member and Estate Management. Any damages and/or breakages and/or losses identified from the comparison will be for the account of the Applicant Member. Estate Management’s determination of the amount payable by the Applicant Member will be final, it being recorded that such amount will not be available at the post-event hand-over meeting.
- 9.7 Estate Management will provide the Applicant Member with a detailed account depicting the cost to rectify and remedy the damages and/or breakages and/or losses identified. This detailed account will be utilised by the Managing Agent as an instruction by the Association to recover the cost to rectify and remedy the damages and/or breakages and/or losses identified from the Applicant Member via the next month’s Member’s levy account.



10. **USE OF THE CLUBHOUSE**

- 10.1 Respect and complete consideration by Members utilising the Clubhouse toward all other Members and Service Providers on the Estate must be exercised at all times. Unreasonable disturbance, inconvenience, annoyance, being a nuisance to, or interference with any Member, or their rights, in any manner deemed by the Association to be unacceptable to harmonious living, is strictly prohibited.
- 10.2 The Association reserves the right to STOP any function, whether a private function or not, should it in its sole discretion consider that any of the RULES of the Association or stipulations of the Clubhouse Policy are breached in any way as to cause a disturbance to other Members on the Estate, or when reasonable complaints pertaining to the use of the Clubhouse are received from other Members on the Estate.
- 10.3 To achieve cost efficiency with regard to electricity consumed at The Viking insofar as the usage of air conditioners is concerned, the air conditioner remotes will be locked away in the store room. Members must request the air conditioner remotes from Social Club Committee members if they know they are going to have a prolonged "stay" at The Viking and return them when their "stay" is complete – please remember to switch the air conditioners off.
- 10.4 Unless a Member has booked the Clubhouse for a Private Function or unless the Association or the Social Committee have booked the Clubhouse for a Community or Business Centre activity, Members are allowed to visit and utilise the Clubhouse and its facilities, cognisant of the Policies contained herein, at any time of day.
- 10.5 Notwithstanding that neither the Association nor the Social Club provides any form of catering to Members for functions, catering facilities and equipment found in the kitchen area of the Clubhouse may be used by Members and/or their caterers.
- 10.6 The Association allows the Members to utilise the crockery, cutlery, glasses and other utensils it owns for use at private functions if requested at the time the booking is made. Should the Member employ a catering service provider and should such service provider, or the Member himself/herself, provide crockery, cutlery, glasses and other utensils for the function, the caterer and/or the Member must remove such items from the Clubhouse premises by 10:00 on the morning following the function in question, it being recorded that the Association will not be responsible for the cleaning/washing of such items.
- 10.7 The following is not permitted in the Clubhouse and is therefore strictly forbidden:
- 10.7.1 Removal of any furniture from the Clubhouse premises, including the moving of furniture from the inside of the Clubhouse to the outside;
- 10.7.2 Lounge furniture (couches, chairs and coffee tables) may not be moved, unless permission is sought from Estate Management, and, if granted, Estate Management is present when the furniture is moved;
- 10.7.3 Café tables and chairs may be moved, but only within the clubhouse and/or pergola area on condition Estate Management is present when such furniture is being moved;
- 10.7.4 Private use by outsiders (non-Members);
- 10.7.5 Smoking in the Clubhouse;



-
- 10.7.6 Fires and/or the use of gas braais or open fire braais (within the Clubhouse building or Pergola area);
- 10.7.7 Sale of alcohol;
- 10.7.8 Serving alcohol to, or consuming of alcohol by, any person under the age of 18 years of age;
- 10.7.9 Discothèques or any other form of amplified music or public address systems;
- 10.7.10 Amplified music being played outside the Clubhouse;
- 10.7.11 Unsupervised children under the age of 18 years of age;
- 10.7.12 Children under the age of 18 years of age may not utilise the pool table;
- 10.7.13 Unlawful gambling;
- 10.7.14 Dogs or other pets;
- 10.7.15 Bicycles, skateboards, rollerblades, one-leg scooters, and any similar toy or device;
- 10.7.16 Attaching any form of décor, signage, banner, logo, poster, display, draping or prop of any nature in any way and means to any part of the infrastructure of the interior or exterior of the Clubhouse
- 10.8 Use of the audio visual facilities of the Clubhouse
- 10.8.1 The audio visual facilities of the Clubhouse consists of:
- 10.8.1.1 a wall mounted television with remote;
- 10.8.1.2 4 wall mounted speakers
- 10.8.1.3 sound components locked in sound cupboard, consisting of:
- 10.8.1.3.1 Dstv Explora with remote
- 10.8.1.3.2 Multi zone sound amplifier with remote
- 10.8.1.3.3 Blue-tooth receiver
- 10.8.2 Members are allowed to utilise the audio visual facilities when visiting the Clubhouse – access to all the items in question will be via the remotes.
- 10.8.3 The following usage times apply to the use of the audio visual equipment and the amplification of the sound it generates, it being recorded that the Member utilising the equipment keep the volume level of the sound at reasonable level:
- | | | | |
|----------|-----------|---|----------------|
| 10.8.3.1 | Sunday | – | 08:00 to 21:00 |
| 10.8.3.2 | Monday | – | 08:00 to 21:00 |
| 10.8.3.3 | Tuesday | – | 08:00 to 21:00 |
| 10.8.3.4 | Wednesday | – | 08:00 to 21:00 |
| 10.8.3.5 | Thursday | – | 08:00 to 21:00 |
| 10.8.3.6 | Friday | – | 08:00 to 23:00 |
| 10.8.3.7 | Saturday | – | 08:00 to 23:00 |
-



11. **USE OF THE GARDEN AREA, PLAYGROUND AND PLAYGROUND FACILITIES**

- 11.1 Respect and complete consideration by Members utilising the Garden area, Playground and Playground facilities toward all other Members and Service Providers on the Estate must be exercised at all times. Unreasonable disturbance, inconvenience, annoyance, being a nuisance to, or interference with any Member, or their rights, in any manner deemed by the Association to be unacceptable to harmonious living, is strictly prohibited.
- 11.2 The Association reserves the right to STOP any function held on the Playground should it in its sole discretion consider that any of the RULES of the Association or the Clubhouse Policy are breached in any way as to cause a disturbance to other Members on the Estate, or when reasonable complaints pertaining to the use of the Playground are received from other Members on the Estate.
- 11.3 The Playground and Playground facilities cannot be booked by any Member for a private function under any circumstances whatsoever. Birthday parties and other children's events are however allowed on the Playground, free of any fee or cost (other than damages and/or breakages and/or losses caused by the Member), it being recorded that adults present at such an event are welcome to use the Clubhouse building during the event. In the event of inclement weather conditions on the day on which a Member hosts an event, the Member may use the Clubhouse building for purposes of candle-lighting and providing meals and drinks to the children, but subject to the following:
- 11.3.1 The Member notifying Estate Management of such intended use, and obtaining his explicit approval;
- 11.3.2 The Member providing sufficient adult supervision for the party, set at one adult for every four children;
- 11.3.3 The children present may not use any of the upholstered furniture or audio visual equipment (especially the remotes) and may not enter the bar and kitchen areas;
- 11.3.4 The Member cleaning the Clubhouse after the party and leaving the Clubhouse in the same state as what it was before the party, but in any event, such cleaning to be completed by no later than 18:00 on the applicable day.
- 11.4 The use of the Playground and Playground facilities is subject to the following conditions:
- 11.4.1 Birthday parties for children to the age of 12 years of age may only be held during the day time to 18:00 on the day of the party;
- 11.4.2 Only children under the age of 12 years of age may make use of the Playground facilities ("Jungle Gyms");
- 11.4.3 Children under the age of 5 years of age using the playground facilities ("Jungle Gyms") must be accompanied by an adult;
- 11.4.4 Chess pieces may only be used for playing chess;
- 11.4.5 The owner of any pet shall immediately remove any excrement deposited by such pet on any area of the Playground;



-
- 11.4.6 Open fire braais are allowed, but the fire must be in a braai or infrastructure item suitable for open fires.
 - 11.5 The following is not permitted on the Playground and is therefore strictly forbidden:
 - 11.5.1 Removal of any furniture from the patio area of the Clubhouse premises, including the moving of furniture from the patio area of the Clubhouse to the garden area of the Playground;
 - 11.5.2 Open fires;
 - 11.5.3 Sale of alcohol;
 - 11.5.4 Serving alcohol to, or consuming of alcohol by, any person under the age of 18 years of age;
 - 11.5.5 Amplified music or the use of public address systems;
 - 11.5.6 Playing in garden beds;
 - 11.5.7 Climbing of trees;
 - 11.5.8 Removal of chess pieces from the playground;
 - 11.5.9 Entry to the area behind the electric fence safety fence;
 - 11.5.10 Children older than 12 years of age may not play on the Playground Facilities ("Jungle Gyms");
 - 11.5.11 Unlawful gambling;
 - 11.5.12 Bicycles, skateboards, rollerblades, one-leg scooters, and any similar toy or device;
 - 11.5.13 The setting off of fireworks and the launching of Chinese Lanterns;
 - 11.5.14 Water slides and water castles.